

# Design GX Control Valve and Actuator System

The Fisher® Design GX is a compact, state-of-the-art control valve and actuator system, designed to control a wide range of process liquids, gases, and vapors.

The Design GX is rugged, reliable, and easy to select. It requires no actuator sizing -- the actuator selection is automatic once the valve body construction is selected.

The optimized design results in reduced complexity and parts count. As a result, the cost of maintenance is reduced.

The Design GX meets the requirements of both EN and ASME standards. It is available with a complete accessory package, including the FIELDVUE® DVC2000 Series integrated digital valve controller.

## Features

- **Easy to size and select**
- **No actuator sizing required--selection is automatic**
- **Engineered for easy maintenance**
- **Maximum part commonality across sizes**
- **Replaceable trim**
- **Low lifetime costs**
- **Robust, low-profile design**
- **Compact field-reversible multi-spring pneumatic actuator**
- **Available with integrated, easy-to-calibrate DVC2000 Series digital valve controller**
- **Valve body sizes DN 15 to DN 150 (0.5 inch through 6-inch)**
- **Pressure Classes PN 10-40, Class 150 and 300**
- **High capacity design**
- **Valve body flow passage optimized for flow stability**
- **Full range of materials, including alloys**
- **Shutoff capabilities: Class IV, V, and VI**
- **Rangeability of 50:1 (equal percentage)**
- **Optional metal bellows seal**



W8861/IL

Figure 1. Design GX Control Valve, Actuator, and DVC2000 Series Digital Valve Controller



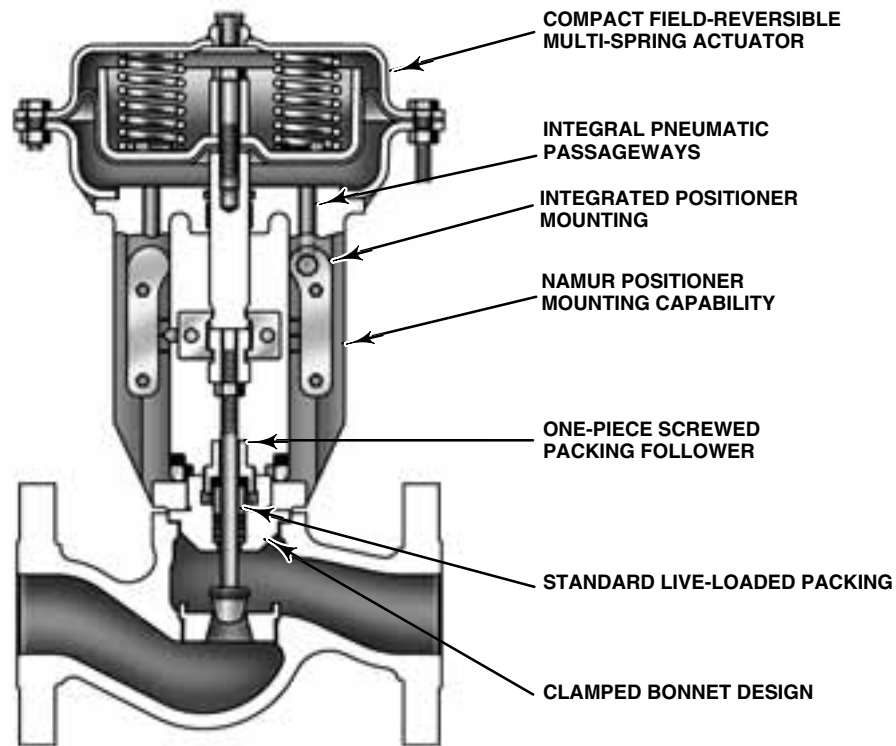

W8486-3/IL

Figure 2. Design GX Control Valve Assembly with Stem-Guided Contoured Plug (Size DN 25/1-Inch)

## Contents

Features .....	1
Principle of Operation .....	4
The Design GX Control Valve .....	5
Design GX Control Valve Specifications and Materials of Construction .....	6
The Design GX Diaphragm Actuator .....	11
Bellows Extension Bonnet .....	13
Valve-Actuator Dimensions and Weights .....	17
Design GX Actuator Accessories .....	18
The FIELDVUE DVC2000 Series	
Digital Valve Controller .....	18
Optional Positioners and Instruments .....	19
Manual Handwheels .....	20
Coefficients .....	22

**Optimized valve and actuator system.** Product simplicity and ease of selection form the foundation of the Design GX. Mounted with a digital or analog positioner, the GX provides high performance control across a wide range of process applications.

**Compact actuator design.** The multi-spring GX actuator is compact and field-reversible. (No extra parts are required to reverse the fail-action). The GX design has been optimized to eliminate complicated actuator sizing procedures - once the valve body and port size are selected, the actuator size is fixed.

**Modular design.** The design architecture has been optimized to maximize the use of common parts across sizes. The actuator stem and stem connector are used across all GX sizes. Only one set of springs is used in each of the two actuator sizes 225 and 750. Size 1200 actuators have two sets of springs, one for 40 mm travel and one for 60 mm travel. The plug/stem assemblies and packing sets are common across several sizes, as well.

**Low lifetime costs.** Reduced product complexity, low parts count, and part commonality all contribute to reduced inventory and maintenance costs.

## Product Bulletin

51.1:GX  
June 2006

# GX Control Valve and Actuator

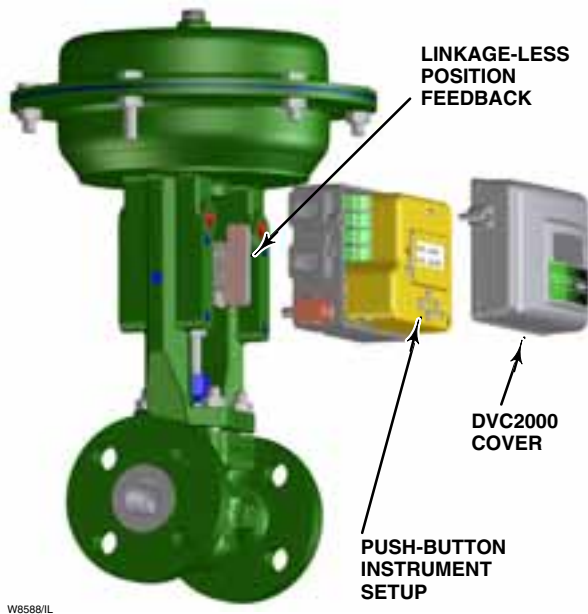

Figure 3. Design GX and DVC2000 Series Digital Valve Controller

**Stable flow control.** The flow cavity of the Design GX valve body has been engineered to provide stable flow and reduce process variability.

**Live-loaded packing.** The Design GX comes with live-loaded PTFE V-ring packing as standard. The live-loaded design helps to seal your process to conserve valuable process fluid, while reducing emissions to the environment. The long-life and high reliability of the live-loaded system also reduces maintenance costs and process downtime. For applications exceeding 232°C (450°F), live-loaded ULF (Ultra Low Friction) graphite packing and extension bonnets are available for all sizes except DN150.

**Easy maintenance.** The simple screwed seat-ring and one-piece plug and stem design provide easy maintenance. Design simplicity and parts commonality contribute to reduced spares inventory. The integrated DVC2000 digital valve controller allows easy instrument removal, without a requirement for tubing disconnection or replacement (air-to-open construction).

**Long life.** Alloy valve constructions and hardened trim materials are available in the Design GX to increase valve body, bonnet, and trim life.

**Digital valve controller.** The Design GX is available with the DVC2000 Series digital valve controller. The

DVC2000 is easy to use, compact, and designed for easy mounting. It converts a 4-20 mA input signal into a pneumatic output signal, which feeds the control valve actuator. Instrument setup is performed with a push button and liquid crystal display (LCD) interface. This interface is protected from the environment within a sealed enclosure. The interface supports multiple languages, including German, French, Italian, Spanish, Chinese, Japanese, and English.

Intrinsic safety and non-incendive construction is available to CSA, FM, ATEX, and IEC standards. An optional module provides integrated limit switches and a position transmitter.

**Integrated mounting.** The DVC2000 digital valve controller integrally mounts to the Design GX actuator, eliminating the need for mounting brackets. The DVC2000 transmits a pneumatic signal to the actuator casing via an air passage in the yoke leg, causing the valve to stroke (see figure 4). This eliminates the need for positioner-to-actuator tubing in the air-to-open (spring-to-close) configuration.

The DVC2000 mounting interface is identical on both sides of the actuator yoke for valve body sizes DN 15 through DN 100 (0.5 inch through 4-inch). This symmetrical design allows the DVC2000 to be easily moved from one side of the valve to the other without the need to rotate the actuator. The DN 150 (6-inch) yoke is not symmetrical.

**Linkage-less feedback.** The DVC2000 digital valve controller offers as standard a non-contacting valve position feedback system. This is a true linkage-less design, which uses no levers and no touching parts between the valve stem and the positioner.

**Additional Accessory selection.** The Design GX is available with a variety of digital or analog positioners besides the DVC2000 Series, as well as solenoid and limit switches. The actuator is also compatible with the IEC 60534-6-1 (NAMUR) positioner mounting standard.

### Note

**Neither Emerson® , Emerson Process Management™ , Fisher, nor any of their affiliated entities assumes responsibility for the selection, use and maintenance of any product. Responsibility for the selection, use, and maintenance of any product remains with the purchaser and end-user.**

## Principle of Operation

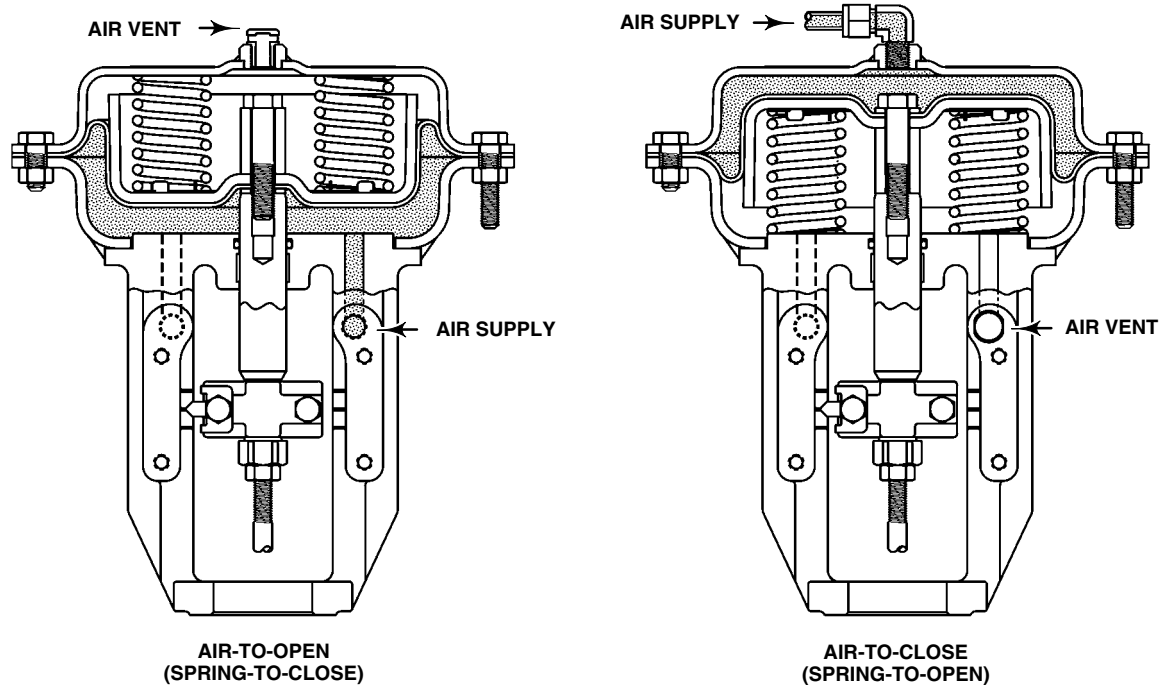

E0896-2/L

Figure 4. Design GX Principle of Operation -- Actuator Air Supply

**Integrated Air Supply.** When mounted with the DVC2000 Series digital valve controller, the Design GX uses an integrated actuator air supply system. In the air-to-open construction, air is supplied to the

lower actuator casing via a port on the actuator yoke face -- no tubing is required. In the air-to-close configuration, air is supplied to the upper casing via tubing.

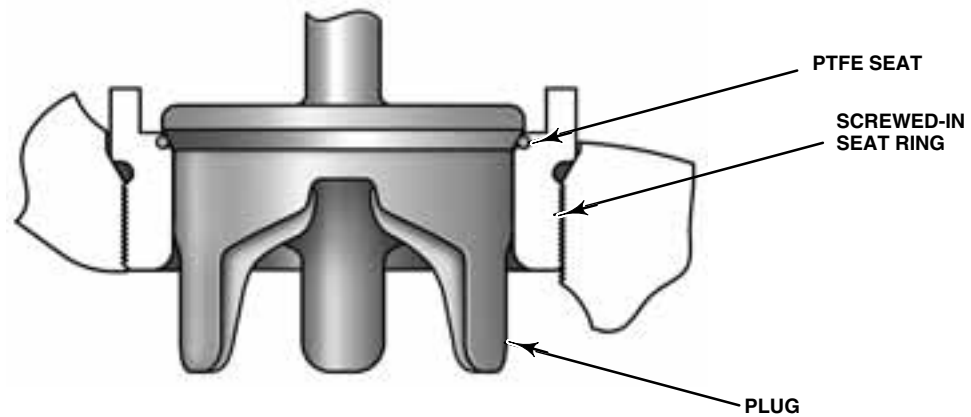

W9023-1

Figure 5. Design GX Control Valve with Typical Soft Seat Trim Construction (Port Sizes of 36 - 136mm)

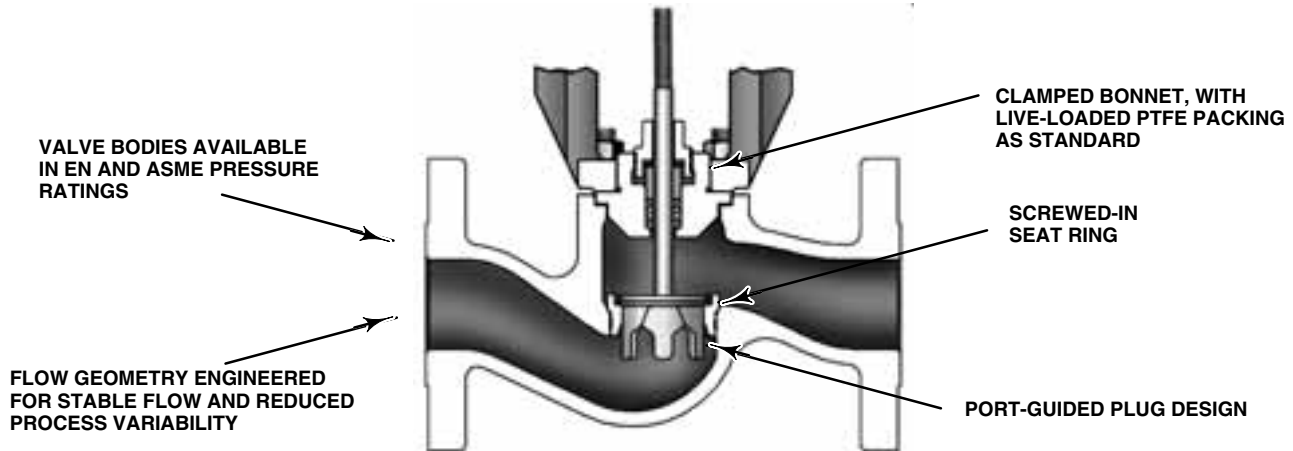

W8568-1/IL

Figure 6. Design GX Control Valve with Port-Guided Plug (Port Sizes of 36 - 136mm)

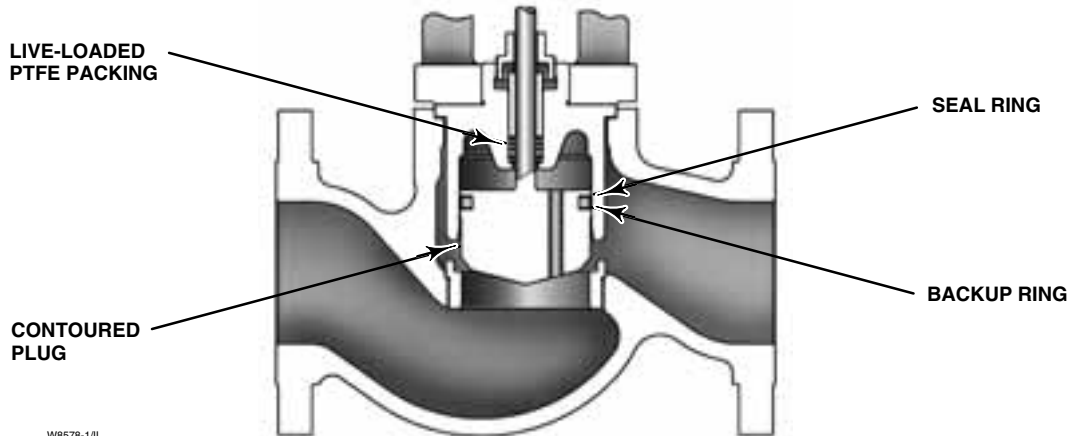

W8578-1/IL

Figure 7. Design GX Control Valve with Balanced Trim (Port Sizes of 70, 90, and 136 mm Only)

### The Design GX Control Valve

The Design GX is a single port, flow-up globe style valve that offers stem-guided, port-guided, and balanced trim with a screwed-in seat ring (see table 1 for a description of trim style availability). Each valve size offers an unbalanced plug design, which eliminates dead spaces where fluid polymerization might occur. Sizes DN80, 100, and 150 (3-, 4-, and 6-inch) also offer balanced trim to reduce actuator thrust requirements.

The Design GX incorporates a clamped bonnet and an easy-to-adjust screwed packing follower (see figure 2). The plug and stem are a rugged, one-piece welded assembly.

The standard construction incorporates metal-to-metal seating, with a PTFE soft seat option

for Class VI shutoff (see figure 5). Class V shutoff is available with metal trim. Hardened trim with stellite overlay is available for erosive service, as well.

PTFE V-ring stem packing is standard with the GX. The live-loaded system provides excellent stem sealing and extended service life. Live-loaded graphite ULF packing and extension bonnets are available for high temperature applications.

Both linear and equal percentage flow characteristics are available in full port and restricted trim. Micro-Flow™ is available for applications requiring low flow control capability.

Standard valve body materials are carbon steel and stainless steel. Alloy materials are available for valve body sizes DN 15 through DN 100 (0.5 through 4-inch) for highly corrosive applications.

## Design GX Control Valve Specifications and Materials of Construction

See tables 1 and 2.

Table 1. Design GX Valve Specifications

Specifications	EN	ASME
Valve Body Size	DN 15, 20, 25, 40, 50, 80, 100, 150	0.5, 0.75, 1, 1.5, 2, 3, 4, 6-inch
Pressure Rating	PN 10 / 16 / 25 / 40 per EN 1092-1	Class 150 / 300 per ASME B16.34
End Connections	Flanged raised face per EN 1092-1	Flanged raised face per ASME B16.5
Valve Body/Bonnet Materials	1.0619 steel	ASME SA216 WCC steel
	1.4409 stainless steel	ASME SA351 CF3M stainless steel
	CW2M (sizes DN 25 through DN 100 only)	CW2M (sizes 1- through 4-inch only)
Face-to-Face Dimensions	Consistent with EN 558-1	Consistent with EN 558-2 (same as ISA S75.03)
Shutoff per IEC 60534-4 and ANSI/FCI 70-2	Metal seat - Class IV (standard)	
	Metal seat - Class V (optional)	
	PTFE seat - Class VI (optional) <sup>(1)</sup>	
Flow Direction	Flow-up only	
Flow Control Characteristics	Equal Percentage and Linear	
Trim Style	Port Diameters	Trim Style Description
	4.8 mm	Micro-Flow trim (unbalanced)
	9.5, 14, 22 mm	Stem-Guided with Contoured Plug (unbalanced)
	36, 46 mm	Port-Guided Plug (unbalanced)
	70, 90, 136 mm	Balanced Trim with Contoured plug (standard) or Unbalanced Port-Guided Plug (optional)
Travel Stop	Available as an option	

1. For 4.8 to 14 mm ports, Class VI shutoff is achieved without PTFE seat.

Table 2. Materials (Other Valve Components)

Component	Material	
Packing Follower	S21800 SST screwed follower	
Body/Bonnet Bolting and Nuts	SA193-B7 studs / SA194-2H nuts with NCF2 coating for carbon steel and stainless steel constructions	
	DN 15 through DN 100: S20910 (XM19) for alloy (standard) and stainless steel assemblies (optional) DN 150: SA193-B7M studs / SA194-2HM nuts with NCF2 coating (optional)	
Packing	Live-loaded PTFE V-ring (standard) with N07718 Belleville springs	
	Live-loaded Graphite ULF (optional) with N07718 Belleville springs	
Bonnet Gasket	DN 15 through DN 150: Graphite laminate	
	DN 15 through DN 100: PTFE encapsulated N10276 (optional) Applicable from -46 to 232°C (-50 to 450°F) (May be preferable when the standard graphite laminate gasket material is not compatible with the process fluid)	
NACE MR0103 Construction	DN 15 through DN 100	Stainless steel, or heat-treated carbon steel valve bodies and bonnets
		SA193-B7 studs / SA194-2H nuts with NCF2 coating (S20910 SST optional) body/bonnet bolting
		Standard live-loaded PTFE packing
	DN 150	S31603/CoCr-A plug, S20910 stem, and S31603/CoCr-A seat ring
Balanced Trim (Sizes DN 80, 100, and 150 / 3-, 4-, and 6-Inch)	Back-up Rings	Carbon-Filled PTFE Seal Ring
		Nitrile (Standard) -46 to 82°C (-50 to 180°F)
		Ethylene Propylene [EPDM] (Optional): -46 to 232°C (-50 to 450°F) in steam and hot water; -46 to 121°C (-50 to 250°F) in air (EPDM is not recommended for use in hydrocarbons)
		FKM Fluoroelastomer (Optional): -18 to 204°C (0 to 400°F) (Applicable in a wide variety of solvents, chemicals, and hydrocarbons. Avoid use with steam, ammonia, or hot water over 82°C [180°F])

*Table 3. Trim Materials for Port Diameters of 4.8 mm (Micro-Flow™ trim) (Unbalanced Trim)*

Valve Body Construction	Trim Type	Stem	Plug	Seat
Carbon steel (1.0619 / WCC)	Metal to metal	S31603 strain hardened	R31233	SA351 CF3M
	Hard-faced	S31603 strain hardened	R31233	SA351 CF3M / CoCr-A seat
	Metal to metal	N06022	R31233	CW2M
Stainless steel (1.4409 / CF3M)	Metal to metal	S31603 strain hardened	R31233	SA351 CF3M
	Hard-faced	S31603 strain hardened	R31233	SA351 CF3M / CoCr-A seat
	Metal to metal	N06022	R31233	CW2M
CW2M	Metal to metal	N06022	R31233	CW2M

*Table 4. Trim Materials for Port Diameters of 9.5 and 14 mm (Unbalanced Trim)*

Valve Body Construction	Trim Type	Stem	Plug	Seat
Carbon steel (1.0619 / WCC)	Metal to metal	S31603 strain hardened	S31603	SA351 CF3M
	Hard-faced	S20910	S31603 / CoCr-A seat	SA351 CF3M / CoCr-A seat
	Metal to metal	N06022	N06022	CW2M
Stainless steel (1.4409 / CF3M)	Metal to metal	S31603 strain hardened	S31603	SA351 CF3M
	Hard-faced	S20910	S31603 / CoCr-A seat	SA351 CF3M / CoCr-A seat
	Metal to metal	N06022	N06022	CW2M
Carbon steel to NACE MR0103 (1.0619 / WCC)	Hard-faced	S20910	S31603 / CoCr-A seat	SA351 CF3M / CoCr-A seat
Stainless steel to NACE MR0103 (1.4409 / CF3M)	Hard-faced	S20910	S31603 / CoCr-A seat	SA351 CF3M / CoCr-A seat
CW2M	Metal to metal	N06022	N06022	CW2M

# GX Control Valve and Actuator

Table 5. Trim Materials for Port Diameters of 22, 36, 46, 70, 90, and 136 mm (Unbalanced Trim)

Valve Body Construction	Trim Type	Stem	Plug	Seat
Carbon steel (1.0619 / WCC)	Metal to metal	S31603 strain hardened	S31603	SA351 CF3M
	Soft seat	S31603 strain hardened	S31603	SA351 CF3M / PTFE seat
	Hard-faced	S20910	S31603 / CoCr-A seat	SA351 CF3M / CoCr-A seat
	Metal to metal	N06022	N06022	CW2M <sup>(1)</sup>
	Soft seat	N06022	N06022	CW2M / PTFE seat <sup>(1)</sup>
Stainless steel (1.4409 / CF3M)	Metal to metal	S31603 strain hardened	S31603	SA351 CF3M
	Soft seat	S31603 strain hardened	S31603	SA351 CF3M / PTFE seat
	Hard-faced	S20910	S31603 / CoCr-A seat	SA351 CF3M / CoCr-A seat
	Metal to metal	N06022	N06022	CW2M <sup>(1)</sup>
	Soft seat	N06022	N06022	CW2M / PTFE seat <sup>(1)</sup>
Carbon steel to NACE MR0103 (1.0619 / WCC)	Hard-faced	S20910	S31603 / CoCr-A seat	SA351 CF3M / CoCr-A seat
Stainless steel to NACE MR0103 (1.4409 / CF3M)	Hard-faced	S20910	S31603 / CoCr-A seat	SA351 CF3M / CoCr-A seat
CW2M	Metal to metal	N06022	N06022	CW2M <sup>(1)</sup>
	Soft seat	N06022	N06022	CW2M / PTFE seat <sup>(1)</sup>

1. Not available for DN 150 (6-inch) size.

Table 6. Trim Materials for Port Diameters of 70, 90, and 136 mm (Balanced Trim)

Valve Body Construction	Trim Type	Stem	Plug	Seat
Carbon steel (1.0619 / WCC) <sup>(1)</sup>	Metal to metal	S31603 strain hardened	S31603	SA351 CF3M
	Hard-faced	S20910	S31603 / CoCr-A seat	SA351 CF3M / CoCr-A seat
	Metal to metal	N06022	N06022	CW2M <sup>(2)</sup>
Stainless steel (1.4409 / CF3M)	Metal to metal	S31603 strain hardened	S31603	SA351 CF3M
	Hard-faced	S20910	S31603 / CoCr-A seat	SA351 CF3M / CoCr-A seat
	Metal to metal	N06022	N06022	CW2M <sup>(2)</sup>
Carbon steel to NACE MR0103 (1.0619 / WCC)	Hard-faced	S20910	S31603 / CoCr-A seat	SA351 CF3M / CoCr-A seat
Stainless steel to NACE MR0103 (1.4409 / CF3M)	Hard-faced	S20910	S31603 / CoCr-A seat	SA351 CF3M / CoCr-A seat
CW2M	Metal to metal	N06022	N06022	CW2M <sup>(2)</sup>

1. The bonnet used in the carbon steel balanced trim construction is made of 1.4409/CF3M stainless steel.  
2. Not available for DN 150 (6-inch) size.

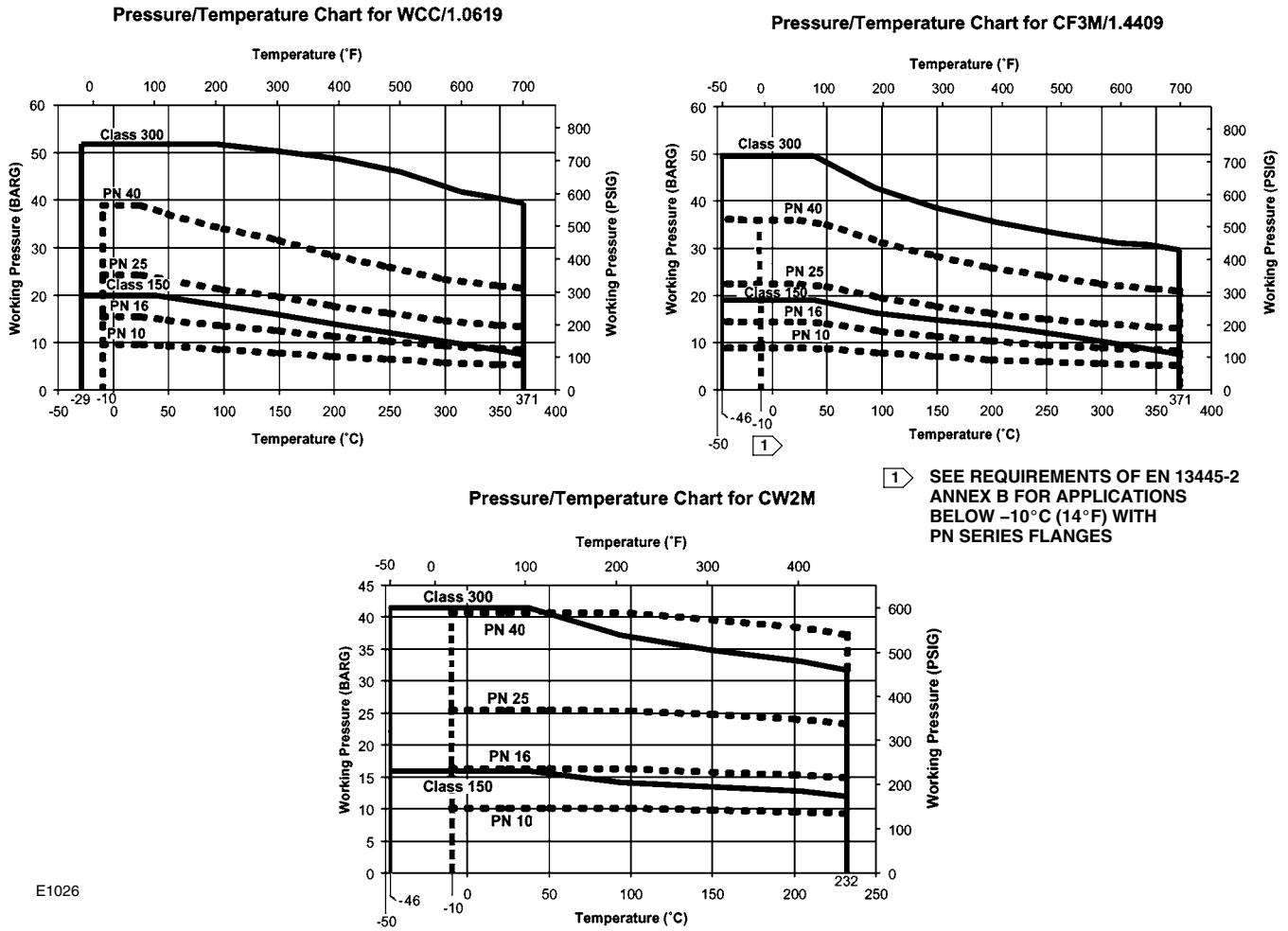

E1026

Figure 8. Material Pressure/Temperature Curves

Table 7. Allowable Temperature Ranges for Valve Body, Bonnet and Trim<sup>(1, 2)</sup>

VALVE BODY / BONNET MATERIAL	BONNET STYLE	PACKING	GASKET	TRIM STYLE	TEMPERATURE			
					°C		°F	
					Min	Max	Min	Max
1.0619/SA216 WCC Steel	Standard	PTFE or Graphite ULF	Graphite laminate or PTFE / N10276	Metal to metal; hard-faced; soft seat	-29 <sup>(3)</sup>	232	-20 <sup>(3)</sup>	450
	Extension	Graphite ULF	Graphite laminate	Metal to metal; hard-faced	-29 <sup>(3)</sup>	371	-20 <sup>(3)</sup>	700
	Bellows	PTFE	Graphite laminate or PTFE / N10276	Metal to metal; hard-faced; soft seat	-29 <sup>(3)</sup>	232	-20 <sup>(3)</sup>	450
		PTFE	Graphite laminate	Metal to metal; hard-faced	-29 <sup>(3)</sup>	371	-50 <sup>(3)</sup>	700
1.4409/SA351 CF3M SST	Standard	PTFE or Graphite ULF	Graphite laminate or PTFE / N10276	Metal to metal; hard-faced; soft seat	-46 <sup>(4)</sup>	232	-50 <sup>(4)</sup>	450
	Extension	Graphite ULF	Graphite laminate	Metal to metal; hard-faced	-46 <sup>(4)</sup>	371	-50 <sup>(4)</sup>	700
	Bellows	PTFE	Graphite laminate or PTFE / N10276	Metal to metal; hard-faced; soft seat	-46 <sup>(4)</sup>	232	-50 <sup>(4)</sup>	450
		PTFE	Graphite laminate	Metal to metal; hard-faced	-46 <sup>(4)</sup>	371	-50 <sup>(4)</sup>	700
CW2M	Standard	PTFE	PTFE / N10276	Metal to metal; soft seat	-46 <sup>(3)</sup>	232	-50 <sup>(3)</sup>	450
	Bellows	PTFE	PTFE / N10276	Metal to metal; soft seat	-46 <sup>(3)</sup>	232	-50 <sup>(3)</sup>	450

1. Applies to all bolting combinations.  
 2. Back-up ring materials used in Sizes DN 80 and 100 (3- and 4-inch) with balanced trim may be limited by temperature and application. See table 2.  
 3. Minimum allowable temperature for PN series flanges is -10°C (14°F).  
 4. See requirements of EN 13445-2 Annex B for applications below -10°C (14°F) with PN series flanges.

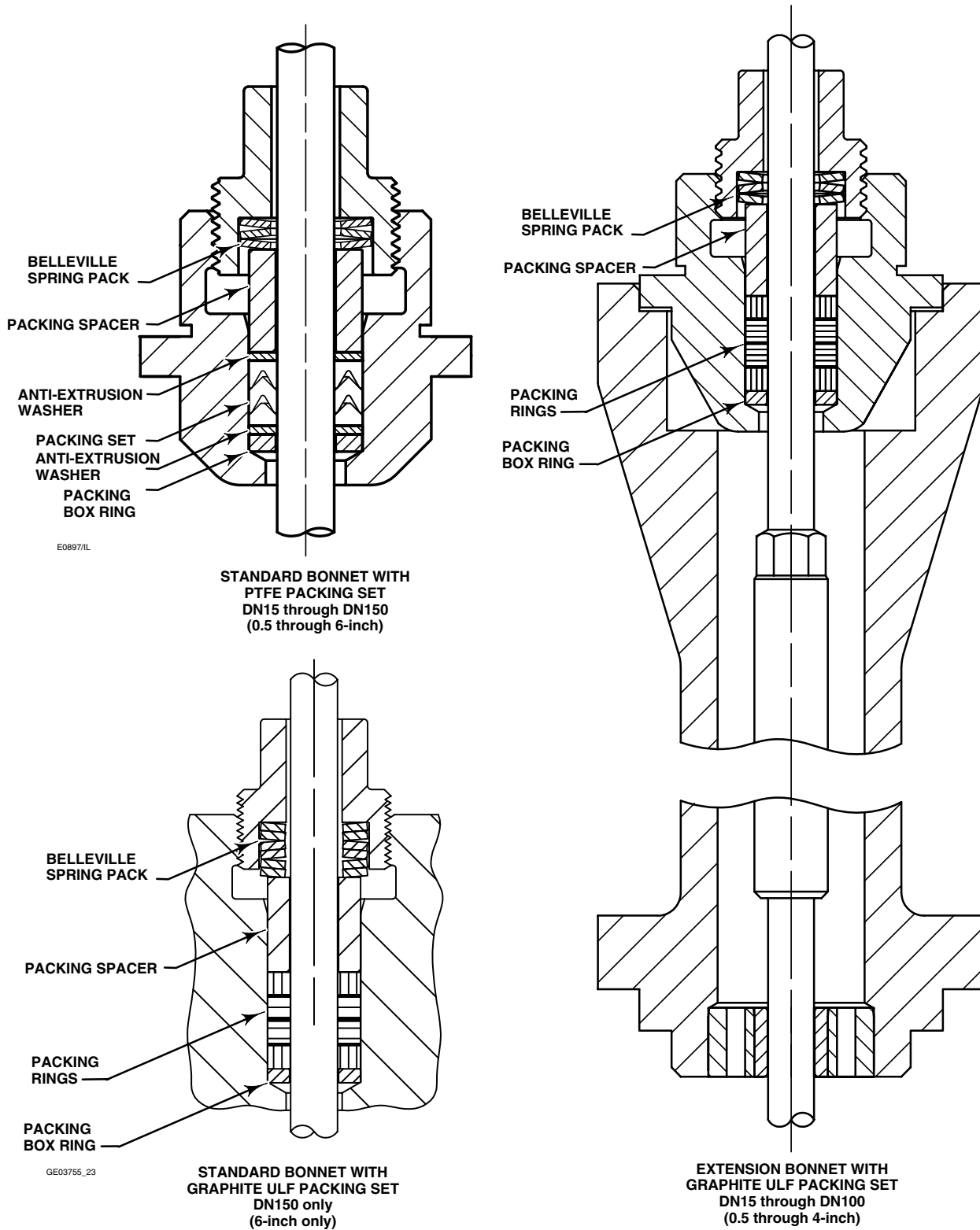

Figure 9. Design GX Packing

## The Design GX Diaphragm Actuator

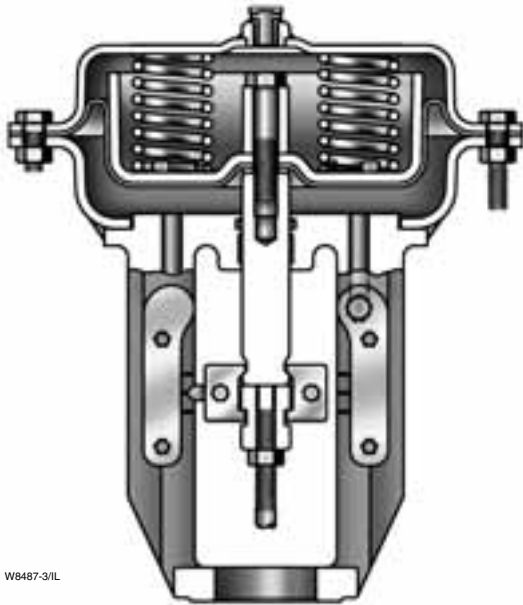

Figure 10. Design GX Actuator

The Design GX uses a multi-spring, pneumatic diaphragm actuator (see figure 10). It is capable of air supply pressures to 6.0 barg (87 psig), allowing valve shutoff at high pressure drops.

The Design GX product selection system automatically matches the actuator to the valve, eliminating the need for complex actuator sizing procedures.

The multiple spring design provides the preload, eliminating the need for bench set adjustment. The actuator is available in spring-to-open and spring-to-close configurations (air-to-close and air-to-open) and is field-reversible.

The GX actuator can be used for throttling or on-off service.

The Design GX is available with the integrated DVC2000 Series digital valve controller. Other digital and analog positioners are available, as well as optional solenoids and limit switches.

Table 8. Actuator Specifications

<b>Description</b>	Pneumatic spring-return diaphragm actuator
<b>Operating Principle</b>	Air-to-close (spring-to-open) Air-to-open (spring-to-close)
<b>Operating Pressure Ranges</b>	3.0 to 6.0 barg (43 to 87 psig) <sup>(1)</sup>
<b>Ambient Temperature</b>	-46 to 82°C (-50 to 180°F)
<b>Pressure Connection (Air-to-Close Construction)</b>	G 1/4 female casing connection
<b>Finish</b>	Powder coat polyester

1. May vary depending on construction (see bulletin 51.1:GX(S1))

Table 9. Materials of Construction

<b>Part</b>	<b>Material</b>
Upper and Lower Casings	AISI G10100 stamped carbon steel
Springs	Steel
Diaphragm	Nitrile and nylon
Diaphragm Plate	Size 225 and 750: AISI G10100 stamped carbon steel Size 1200: Cast carbon steel
Yoke	Carbon steel (stainless steel optional for some sizes)
Casing Fasteners	A2-70 stainless steel bolts and nuts
Actuator Rod	Stainless steel
Stem Connector	CF3M
Stem Connector Fasteners	SA193-B7 bolts with NCF2 coating
Stem Bushing	High-density polyethylene (HDPE)
Stem Seal	Nitrile

## Actuator Selection

With the Design GX, actuator selection has never been easier. Once the valve size and port diameter have been determined, the actuator is automatically selected. No spring selection or bench set calculations are required.

The following tables provide the maximum allowable

pressure drops for the Design GX (see tables 10 and 11). The majority of GX constructions (both air-to-open and air-to-close) are rated to a full pressure class shutoff capability of 51.7 bar (750 psi) for a 4 to 6 bar (58 to 87 psig) actuator air supply. (For CW2M trim or actuator air supply pressures of less than 4 bar (58 psig), refer to Fisher bulletin 51.1:GX (S1) for additional information.)

Table 10. Actuator Pressure Drop Capability For S31603 Trim (with S31603 or S20910 stem) in Standard, Extension, and Bellows Bonnet Constructions with 4-6 bar (58-87 psi) Actuator Air Supply<sup>(1, 2, 3)</sup>

VALVE SIZE	PORT SIZE (mm)	TRIM STYLE	SHUTOFF CAPABILITY
DN15 to DN100 (0.5 to 4 Inch)	4.8 to 46	Unbalanced	Full Pressure Class ΔP <sup>(4)</sup>
DN80 to DN150 (3 to 6-Inch)	70 to 136	Balanced	Full Pressure Class ΔP <sup>(4)</sup>
DN80 to DN150 (3 to 6-Inch)	70 to 136	Unbalanced	See table 11

1. For both air-to-open and air-to-close constructions. Some air-to-close actuator air supply restrictions exist. See Fisher bulletin 51.1:GX (S1) for additional information.  
 2. For CW2M trim or supply pressures less than 4 bar (58 psi), see Fisher bulletin 51.1:GX (S1) for additional information.  
 3. Applies to both PTFE and Graphite ULF packing.  
 4. Actuator is capable to 51.7 bar (750 psi) pressure drop. Some air-to-close actuator air supply restrictions exist. See Fisher bulletin 51.1:GX (S1) for additional information.

Table 11. Size 1200 Actuator Pressure Drop Capability For Unbalanced S31603 Trim (with S31603 or S20910 stem) in Standard and Extension Bonnet Constructions at 4-6 bar (58-87 psi) Supply<sup>(1)</sup>

Valve Size	Bonnet Style	Port Size	Packing	MAXIMUM ALLOWABLE PRESSURE DROP					
				Air-to-Open		Air-to-Close			Maximum Pressure Drop @ Maximum Actuator Supply Pressure
				3-6 bar (44-87 psi)	4 bar (58 psi)	5 bar (73 psi)	6 bar (87 psi)		
mm	Bar (psi)	Bar (psi)	Bar (psi)	Bar (psi)					
DN80 / 3 Inch	Standard	70	Graphite ULF	32.6 (472)	51.7 (750)		---	51.7 bar @ 5.6 bar supply max (750 psi @ 81 psi supply max)	
			PTFE	33.1 (480)	51.7 (750)		---		
	Extension	70	Graphite ULF	32.6 (472)	51.7 (750)	---	---	51.7 bar @ 4.2 bar supply max (750 psi @ 61 psi supply max)	
			PTFE	33.1 (480)	51.7 (750)	---	---		
DN100 / 4 Inch	Standard	70	Graphite ULF	32.6 (472)	51.7 (750)		---	51.7 bar @ 5.6 bar supply max (750 psi @ 81 psi supply max)	
			PTFE	33.1 (480)	51.7 (750)		---		
		90	Graphite ULF	19.7 (286)	28.5 (414)	51.7 (750)	---	51.7 bar @ 5.6 bar supply max (750 psi @ 81 psi supply max)	
			PTFE	20.0 (290)	28.8 (418)	51.7 (750)	---		
	Extension	70	Graphite ULF	32.6 (472)	51.7 (750)	---	---	51.7 bar @ 4.2 bar supply max (750 psi @ 61 psi supply max)	
			PTFE	33.1 (480)	51.7 (750)	---	---		
		90	Graphite ULF	19.7 (286)	28.5 (414)	---	---	32.1 bar @ 4.2 bar supply max (466 psi @ 61 psi supply max)	
			PTFE	20.0 (290)	28.8 (418)	---	---		32.5 bar @ 4.2 bar supply max (471 psi @ 61 psi supply max)
DN150 / 6 Inch	Standard	90	Graphite ULF	17.9 (260)	26.7 (387)	44.8 (650)	---	51.7 bar @ 5.6 bar supply max (750 psi @ 81 psi supply max)	
			PTFE	19.6 (284)	28.5 (414)	51.7 (750)	---		
		136	Graphite ULF	7.8 (113)	11.7 (170)	19.6 (284)	---	24.4 bar @ 5.6 bar supply max (354 psi @ 81 psi supply max)	
			PTFE	8.6 (125)	12.5 (181)	20.4 (296)	---	25.1 bar @ 5.6 bar supply max (364 psi @ 81 psi supply max)	

1. For CW2M trim or supply pressures less than 4 bar (58 psi), see Fisher bulletin 51.1:GX (S1) additional information.

## Bellows Extension Bonnet

The Design GX bellows extension bonnet provides reliable and tight stem sealing for those applications where emissions escaping to the environment cannot be tolerated (see figure 11). The GX bellows is available in SST (1.4571 / 316Ti) or N10276 and covers a full range of valve sizes from DN 15 through DN 100 (0.5 through 4-inch) (see tables 12 and 13).

**The GX bellows system has been designed for 100,000 full-travel cycles at maximum allowable pressure and ambient temperature (20°C [68°F]).**

The mechanically-formed metal bellows provides high operating reliability and extended cycle life (see tables 14, 15, and 16 for details).

The GX bellows design incorporates a rugged double- or triple-wall construction for added security. Each bellows has been tested with helium before it leaves the factory.

The GX bellows bonnet comes standard with a live-loaded, PTFE packing system as a security backup. A connection is provided above the bellows to allow purging or monitoring the integrity of the replaceable bellows.

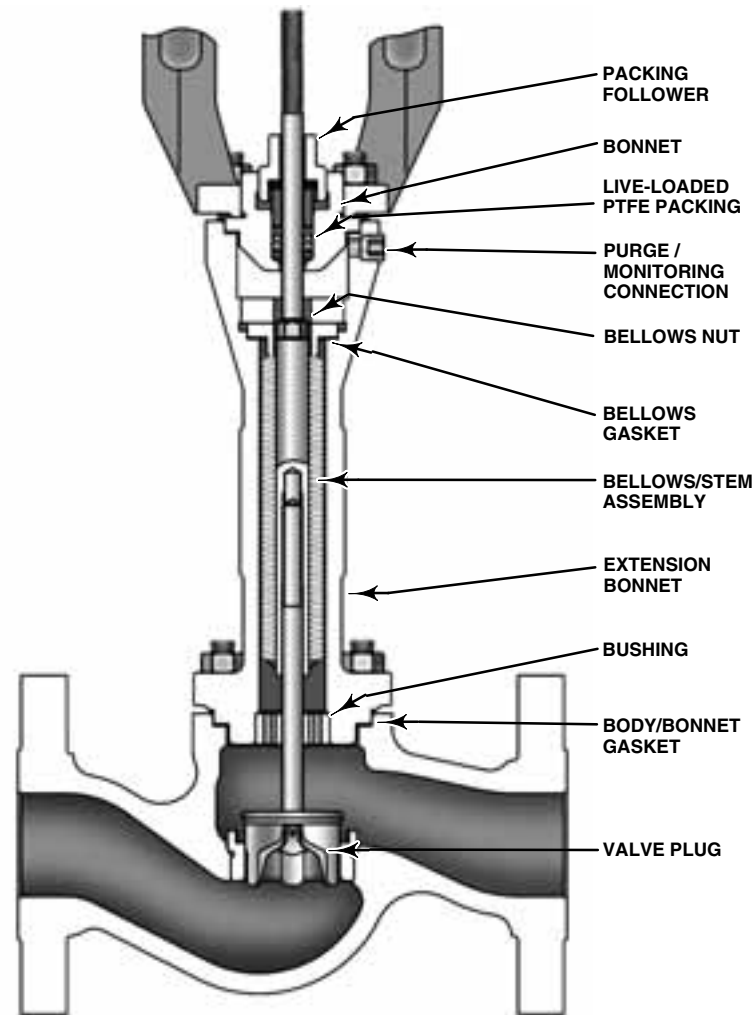

W8958-1

### Bellows Selection Process

Follow this process to assist in selecting the appropriate bellows for the application.

#### Step 1

Size and select the Design GX control valve that is appropriate for the application. This will identify the:

- Valve body size
- Actuator size
- Orifice size
- Trim style (balanced or unbalanced)
- Valve body material



#### Step 2

Confirm bellows availability from table 12.



#### Step 3

Using table 13, select the bellows material combination that is appropriate for the application. Using the temperature limits shown in table 7, confirm the selected construction is appropriate for the application temperatures.



#### Step 4

Using table 10 or bulletin 51.1:GX(S1), verify the application pressure drop does not exceed the actuator capability.



#### Step 5

Using figure 12, check to ensure the maximum process pressure and temperature do not exceed the pressure-temperature rating of the selected bellows.

Figure 11. Design GX Bellows Bonnet and Selection Process

# GX Control Valve and Actuator

Table 12. GX Constructions with Bellows Availability

VALVE BODY SIZES	PORT SIZE (mm)	ACTUATOR SIZES	PLUG TRAVEL	TRIM STYLE
DN15-50 (0.5 to 2-Inch)	4.8 to 46	225 and 750	20 mm	Unbalanced
DN80 (3-Inch)	36 to 46	750	20 mm	Unbalanced
	70	750	20 mm	Balanced
DN100 (4-Inch)	46	750	20 mm	Unbalanced
	90	750	20 mm	Balanced

Table 13. Bellows Materials of Construction

Valve Body / Bonnet	Bellows	Bellows Stem Extension	Trim Materials		Bolting	Packing	Gaskets	Lower Bushing	Monitoring Connection Plug
			Plug <sup>(1)</sup>	Stem Material					
Carbon Steel (1.0619/WCC)	SST (1.4571/316Ti)	S31603	S31603 or CF3M	S31603	SA193-B7 with NCF2 coating	Live-loaded PTFE	Graphite laminate	S31600 with R31233 insert	S31600
	N10276	S31603	S31603 or CF3M	S31603	SA193-B7 with NCF2 coating	Live-loaded PTFE	Graphite laminate	S31600 with R31233 insert	S31600
	N10276	N06022	N06022 or CW2M	N06022	S20910	Live-loaded PTFE	PTFE encapsulated N10276	N10276 with R31233 insert	N10276
Stainless Steel (1.4409/CF3M)	SST (1.4571/316Ti)	S31603	S31603 or CF3M	S31603	S20910	Live-loaded PTFE	Graphite laminate	S31600 with R31233 insert	S31600
	N10276	S31603	S31603 or CF3M	S31603	S20910	Live-loaded PTFE	Graphite laminate	S31600 with R31233 insert	S31600
	N10276	N06022	N06022 or CW2M	N06022	S20910	Live-loaded PTFE	PTFE encapsulated N10276	N10276 with R31233 insert	N10276
CW2M	N10276	N06022	N06022 or CW2M	N06022	S20910	Live-loaded PTFE	PTFE encapsulated N10276	N10276 with R31233 insert	N10276

1. Plug material for the 4.8 mm port is R31233.

For bellows height dimensions, see table 18.

# Product Bulletin

51.1:GX  
June 2006

# GX Control Valve and Actuator

## Cycle Life

Bellows service life is affected by several factors, including process pressure, temperature, and plug travel. Tables 14, 15, 16, and 17 provide estimates of cycle life for several cases.

Table 14. Estimated Bellows Cycle Life at 10.3 bar (150 psig) and 20 °C (68 °F)

VALVE SIZE	STEM SIZE	BELLOWS MATERIAL	PLYS	BELLOWS PRESSURE	PROCESS TEMPERATURE		ESTIMATED CYCLE LIFE (50% Stroke [25-75% travel])
					°C	°F	
DN15-50 (0.5 to 2-Inch)	10mm	1.4571 (316Ti)	2	10.3 bar (150 psig)	20	68	1,040,000
		N10276	3	10.3 bar (150 psig)	20	68	910,000
DN80-100 (3 to 4-Inch)	14mm	1.4571 (316Ti)	2	10.3 bar (150 psig)	20	68	1,020,000
		N10276	2	10.3 bar (150 psig)	20	68	980,000

Table 15. Estimated Bellows Cycle Life at Bellows Maximum Allowable Pressure and 20 °C (68 °F)

VALVE SIZE	STEM SIZE	BELLOWS MATERIAL	PLYS	MAXIMUM ALLOWABLE BELLOWS PRESSURE <sup>(1)</sup>	PROCESS TEMPERATURE		ESTIMATED CYCLE LIFE (50% Stroke [25-75% travel])
					°C	°F	
DN15-50 (0.5 to 2-Inch)	10mm	1.4571 (316Ti)	2	40 bar (580 psig)	20	68	830,000
		N10276	3	51.7 bar (750 psig)	20	68	800,000
DN80-100 (3 to 4-Inch)	14mm	1.4571 (316Ti)	2	45 bar (650 psig)	20	68	800,000
		N10276	2	51.7 bar (750 psig)	20	68	810,000

1. Valve maximum allowable pressure drop may be limited by size and material. See GX bulletin 51.1:GX(S1) for additional information.

Table 16. Estimated Bellows Cycle Life at Bellows Maximum Allowable Pressure and 232 °C (450 °F)

VALVE SIZE	STEM SIZE	BELLOWS MATERIAL	PLYS	MAXIMUM ALLOWABLE BELLOWS PRESSURE <sup>(1)</sup>	PROCESS TEMPERATURE		ESTIMATED CYCLE LIFE (50% Stroke [25-75% travel])
					°C	°F	
DN15-50 (0.5 to 2-Inch)	10mm	1.4571 (316Ti)	2	29.8 bar (430 psig)	232	450	410,000
		N10276	3	47.2 bar (685 psig)	232	450	560,000
DN80-100 (3 to 4-Inch)	14mm	1.4571 (316Ti)	2	33.5 bar (485 psig)	232	450	390,000
		N10276	2	47.2 bar (685 psig)	232	450	550,000

1. Valve maximum allowable pressure drop may be limited by size and material. See GX bulletin 51.1:GX(S1) for additional information.

Table 17. Estimated Bellows Cycle Life at Bellows Maximum Allowable Pressure and 371 °C (700 °F)

VALVE SIZE	STEM SIZE	BELLOWS MATERIAL	PLYS	MAXIMUM ALLOWABLE BELLOWS PRESSURE	PROCESS TEMPERATURE		ESTIMATED CYCLE LIFE (50% Stroke [25-75% travel])
					°C	°F	
DN15-50 (0.5 to 2-Inch)	10mm	1.4571 (316Ti)	2	26.1 bar (380 psig)	371	700	250,000
		N10276	3	39.3 bar (570 psig)	371	700	430,000
DN80-100 (3 to 4-Inch)	14mm	1.4571 (316Ti)	2	29.3 bar (425 psig)	371	700	240,000
		N10276	2	39.3 bar (570 psig)	371	700	430,000

## Bellows Pressure - Temperature Ratings

See figure 12.

**Pressure - Temperature Ratings for 1.4571 (316Ti) Bellows**

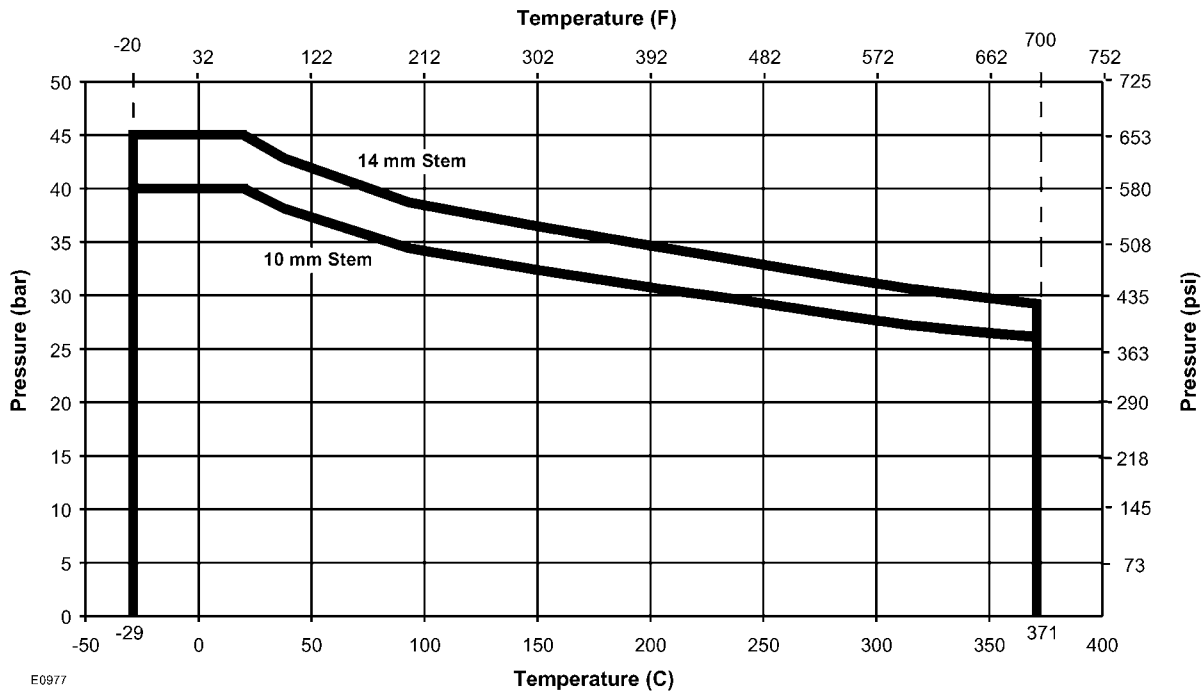

**Pressure-Temperature Ratings for N10276 Bellows**

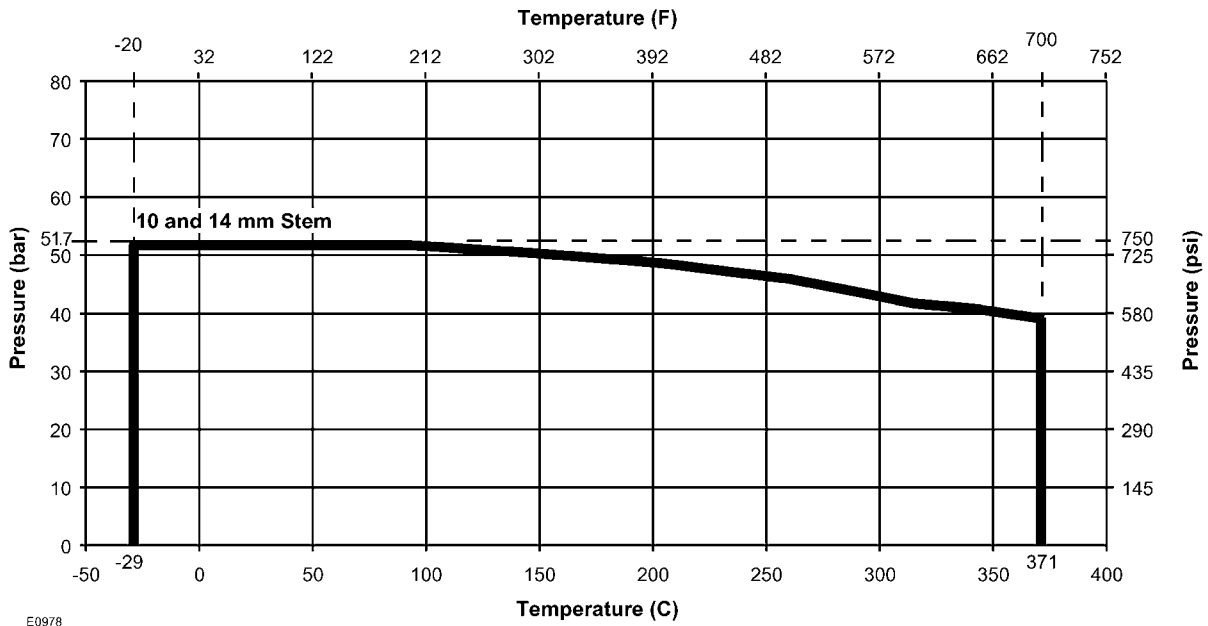

Figure 12. Bellows Pressure - Temperature Ratings

Valve-Actuator Dimensions and Weights

See figure 13 and table 18.

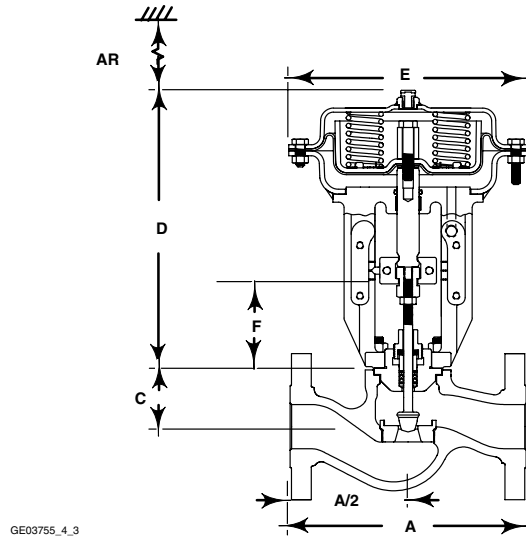

Figure 13. Design GX Dimensions (also see table 18)

Table 18. Design GX Dimensions and Weights

VALVE SIZE	PORT DIA	ACTUATOR SIZE	A			C		D		E Casing Dia	F (AR) Removal Height <sup>(3)</sup>	TOTAL WEIGHT	
			PN10 - PN40	Class 150	Class 300	Std Bonnet	Extension or Bellows Bonnet	Actuator Height (Standard Bonnet)	Actuator Height (Extension or Bellows Bonnet)			With Standard Bonnet	With Extension or Bellows Bonnet
			mm	mm	mm	mm	mm	mm	mm			kg	kg
DN 15/ 0.5 Inch	4.8	225	130	184	190	66	304	313	313	270	115	21	25
	9.5	225	130	184	190	66	304	313	313	270	115	21	25
DN 20/ 0.75 Inch	4.8	225	150	184	194	66	304	313	313	270	115	22	26
	9.5	225	150	184	194	66	304	313	313	270	115	22	26
	14	225	150	184	194	66	304	313	313	270	115	22	26
DN 25/ 1-Inch	4.8	225	160	184	197	58	296	313	313	270	115	22	26
	9.5	225	160	184	197	58	296	313	313	270	115	22	26
	14	225	160	184	197	58	296	313	313	270	115	22	26
	22	225	160	184	197	58	296	313	313	270	115	22	26
DN 40/ 1.5 Inch	14	225	200	222	235	62	300	313	313	270	115	25	29
	22	225	200	222	235	62	300	313	313	270	115	25	29
	36	750	200	222	235	62	300	342	342	430	115	52	56
DN 50/ 2-Inch	22	225	230	254	267	68	306	313	313	270	115	29	33
	36	750	230	254	267	68	306	342	342	430	115	56	60
	46	750	230	254	267	68	306	342	342	430	115	56	60
DN 80/ 3-Inch	36	750	310	298	318	105	373	375	375	430	125	79	88
	46	750	310	298	318	105	373	375	375	430	125	79	88
	70 <sup>(1)</sup>	750	310	298	318	105	373 <sup>(4)</sup>	375	375	430	125	81	90
	70	1200	310	298	318	105	373	458	458	566	125	131	140
DN 100/ 4-Inch	46	750	350	352	368	121	393	379	375	430	130	98	109
	70	1200	350	352	368	121	393	462	458	566	130	150	161
	90 <sup>(2)</sup>	750	350	352	368	121	393 <sup>(4)</sup>	379	375	430	130	105	115
	90 <sup>(1)</sup>	750	350	352	368	121	393 <sup>(4)</sup>	379	375	430	130	105	115
	90	1200	350	352	368	121	393	462	458	566	130	150	161
DN 150/ 6-Inch	136	1200	450 <sup>(5)</sup>	451	473	189	---	559	---	566	224	235	---
	136 <sup>(1)</sup>	1200	450 <sup>(5)</sup>	451	473	200	---	559	---	566	210	247	---
	136 <sup>(6)</sup>	1200	450 <sup>(5)</sup>	451	473	230	---	589	---	566	240	247	---

1. Balanced trim design.  
 2. Balanced trim with reduced-capacity plug.  
 3. Clearance required for removing actuator from installed valve body.  
 4. Bellows bonnets are available for these constructions. However, extension bonnets are not available with balanced trim due to temperature limitations of the trim seals.  
 5. PN25 / 40  
 6. Severe service.

Table 19. Positioner Selection Guidelines

Type	Digital I/P <sup>(1)</sup>	I/P <sup>(2)</sup>	P/P <sup>(3)</sup>	Intrinsic Safety <sup>(4)</sup>	Flameproof / Explosionproof <sup>(4)</sup>	Non- Incendive <sup>(4)</sup>
DVC2000	X			X		X
DVC6030	X			X	X	X
3661		X		X		X
3660			X			

1. Digital I/P - microprocessor based electro-pneumatic with HART communication.  
2. I/P - electro-pneumatic  
3. P/P - pneumatic  
4. Refer to Fisher bulletin 9.2:001 for instrument hazardous area classification details.

## Design GX Actuator Accessories

The Design GX is available with a variety of pneumatic (P/P), electro-pneumatic (I/P), and digital valve positioners, as well as limit switches and solenoids. Table 19 provides the basic features of the positioners offered with the Design GX actuator.

## The FIELDVUE® DVC2000 Series Digital Valve Controller

The DVC2000 Series digital valve controller (figure 14) is simple to use, compact, and designed for the GX control valve. It converts a 4-20mA input signal into a pneumatic output signal, which feeds the control valve actuator. Instrument setup is performed with a pushbutton and liquid crystal display (LCD) interface. This interface is protected from the environment within an IP66 enclosure. Multiple languages are supported with the local interface including German, French, Italian, Spanish, Chinese, Japanese, and English. Additionally, HART® communication is supported over the 4-20mA loop wiring.

The DVC2000 is designed to be integrally mounted to the Design GX actuator, avoiding the need for mounting brackets. The DVC2000 mounts directly to an interface pad on the actuator yoke leg with a secure 3-point mounting. An internal passage inside the yoke leg transmits the pneumatic signal to the actuator casing, eliminating the need for external tubing (in the air-to-open configuration).



W8755

Figure 14. FIELDVUE® DVC2000 Series Digital Valve Controller

The high-performance linkage-less position feedback system eliminates physical contact between the valve stem and the positioner. There are no wearing parts so cycle life is maximized. Additionally, the elimination of levers and linkages reduces the number of mounting parts and the mounting complexity. Positioner replacement and maintenance is simplified because the feedback parts stay connected to the actuator.

The DVC2000 Series is available with an optional module which includes two (2) integral limit switches and a stem position transmitter. The limit switches are configurable for open and closed valve indication. The position transmitter provides a 4-20mA signal for valve position feedback verification. As an integral component to the instrument, this option module avoids the need for difficult-to-mount external switches and transmitters.

Designed to meet intrinsic safety and non-incendive requirements, this instrument delivers scalable functionality and high performance in a small package.

## Optional Positioners and Instruments

### Type 3660 and 3661 Valve Positioners

The Type 3660 pneumatic and 3661 electro-pneumatic positioners are rugged, accurate, and feature low steady-state air consumption. Designed to meet intrinsic safety requirements, these positioners offer simple functionality in a small package. (See figure 15 and table 19.)

### Type DVC6030 Digital Valve Controller

The Type DVC6030 digital valve controller is a communicating, microprocessor-based positioner. Using HART or FOUNDATION™ fieldbus communication protocol, access to critical instrument, valve, and process conditions is provided. When used with AMS ValveLink® Software, valve diagnostic tests can be run while the valve is in service to advise you of the performance of the entire control valve assembly. Designed to meet a broad range of hazardous area classifications, this positioner offers maximum functionality to improve your process performance. (See figure 16 and table 19.)



W8590/L

Figure 15. Design GX Valve with Type 3660 or 3661 Positioner, NAMUR Mounting (IEC 60534-6-1)



W7963-1/L

Figure 16. Type DVC6030

# GX Control Valve and Actuator

## Manual Handwheels

The Design GX is available with an optional, side-mounted manual handwheel (see figure 17). These handwheels provide a robust method of manually operating the valve in an emergency or upon loss of instrument air.

The GX handwheel will stroke the valve up to 20mm travel, and is available on the size 225 and 750

actuators. Dimensions are provided in figure 18 and table 20.

When mounted to an air-to-close (spring-to-open) actuator, rotating the handwheel clockwise moves the stem downwards. When mounted to an air-to-open (spring-to-close) actuator, turning the handwheel in the clockwise direction causes the stem to move upwards. Disengagement of the handwheel to allow automatic operation is accomplished by simply rewinding the handwheel.



W9025

Figure 17. Design GX Control Valve and Actuator System with Manual Handwheel

**Product Bulletin**

51.1:GX  
June 2006

# GX Control Valve and Actuator

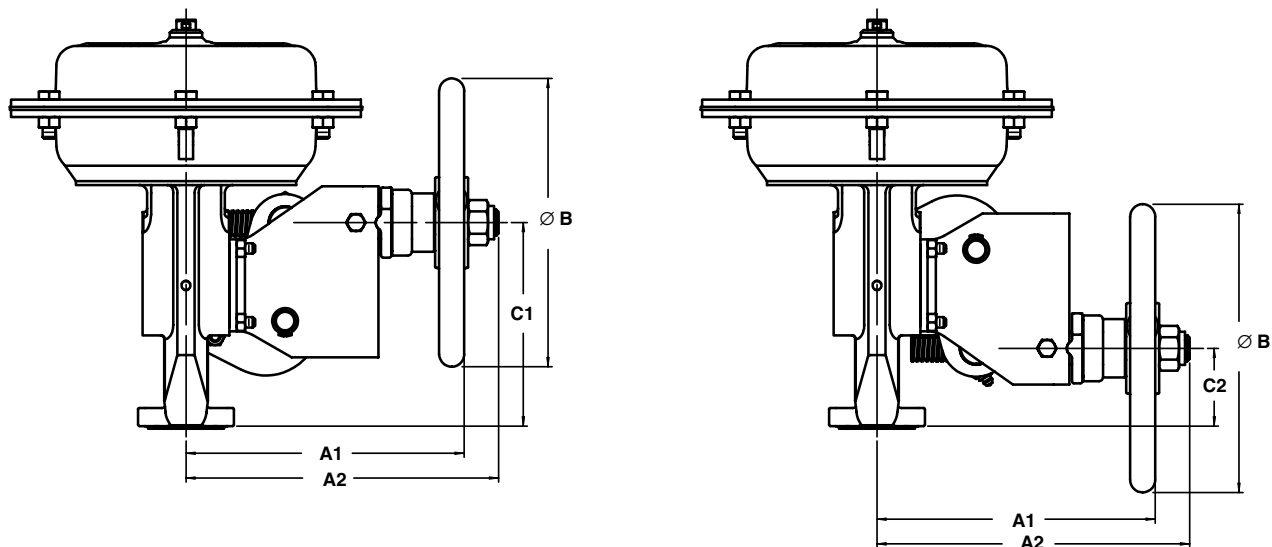

E0975

Figure 18. Design GX with Handwheel Dimensions (also see table 20)

Table 20. Design GX with Handwheel Dimensions and Weights

VALVE SIZE		ACTUATOR SIZE	VALVE TRAVEL mm	HANDWHEEL WEIGHT kg	A1 mm	A2 mm	B mm	C1 <sup>(1)</sup> mm	C2 <sup>(2)</sup> mm
EN	ASME Inches								
DN 15	0.5	225	20	5.6	215	242	223	159	60
DN 20	0.75	225	20	5.6	215	242	223	159	60
DN 25	1	225	20	5.6	215	242	223	159	60
DN 40	1.5	225	20	5.6	215	242	223	159	60
		750	20	12.2	293	317	356	159	60
DN 50	2	225	20	5.6	215	242	223	159	60
		750	20	12.2	293	317	356	159	60
DN 80	3	750	20	12.2	293	317	356	169	70
DN 100	4	750	20	12.2	293	317	356	173	74
DN 150	6	1200	Contact your Emerson Process Management sales office for information.						

1. C1 is Air-to-Open, Spring-to-Close.  
2. C2 is Air-to-Close, Spring-to-Open.

## Coefficients

Table 21. Design GX, Equal Percentage Valve Plug, Flow Up Through the Port

Equal Percentage - Flow Up													Equal Percentage Characteristic	
Valve Size	Port Diameter mm	Maximum Travel mm	Flow Coefficient	Valve Opening—Percent of Total Travel										F <sub>L</sub> <sup>(1)</sup>
				10	20	30	40	50	60	70	80	90	100	
DN 15 (0.5 Inch)	9.5	20	C <sub>V</sub>	0.118	0.191	0.309	0.457	0.607	0.941	1.39	2.00	2.77	3.34	0.98
			K <sub>V</sub>	0.102	0.166	0.267	0.396	0.525	0.814	1.20	1.73	2.40	2.89	---
			X <sub>T</sub>	0.67	0.59	0.58	0.56	0.57	0.55	0.57	0.57	0.61	0.69	---
			F <sub>d</sub>	0.11	0.13	0.16	0.19	0.22	0.28	0.34	0.44	0.58	0.80	---
	9.5 <sup>(2)</sup>	20	C <sub>V</sub>	0.089	0.109	0.153	0.213	0.289	0.393	0.552	0.754	1.03	1.43	0.99
			K <sub>V</sub>	0.077	0.094	0.132	0.185	0.250	0.340	0.478	0.652	0.891	1.24	---
			X <sub>T</sub>	0.72	0.65	0.61	0.59	0.57	0.54	0.53	0.55	0.55	0.59	---
			F <sub>d</sub>	0.09	0.09	0.09	0.11	0.13	0.14	0.20	0.24	0.28	0.35	---
DN 20 (0.75 Inch)	14	20	C <sub>V</sub>	0.154	0.192	0.311	0.505	0.763	1.18	1.91	3.05	4.93	6.41	0.98
			K <sub>V</sub>	0.133	0.166	0.269	0.437	0.660	1.02	1.65	2.64	4.27	5.55	---
			X <sub>T</sub>	0.62	0.60	0.58	0.59	0.52	0.54	0.54	0.62	0.71	0.77	---
			F <sub>d</sub>	0.08	0.08	0.10	0.13	0.16	0.20	0.26	0.33	0.47	0.59	---
	9.5	20	C <sub>V</sub>	0.128	0.206	0.325	0.479	0.629	0.984	1.46	2.14	3.06	3.75	0.95
			K <sub>V</sub>	0.111	0.178	0.281	0.415	0.544	0.851	1.27	1.85	2.65	3.25	---
			X <sub>T</sub>	0.65	0.66	0.62	0.61	0.62	0.65	0.64	0.63	0.65	0.62	---
			F <sub>d</sub>	0.11	0.13	0.16	0.19	0.22	0.28	0.34	0.44	0.58	0.80	---
	9.5 <sup>(2)</sup>	20	C <sub>V</sub>	0.127	0.149	0.176	0.222	0.311	0.440	0.599	0.828	1.14	1.65	0.97
			K <sub>V</sub>	0.110	0.129	0.153	0.192	0.269	0.381	0.518	0.716	0.985	1.43	---
			X <sub>T</sub>	0.69	0.77	0.68	0.81	0.76	0.71	0.72	0.67	0.75	0.79	---
			F <sub>d</sub>	0.09	0.09	0.09	0.11	0.13	0.14	0.20	0.24	0.28	0.35	---

1. At 100% travel.
2. Restricted trim.
3. Balanced trim.
4. Balanced, restricted trim.

-continued-

Table 21. Design GX, Equal Percentage Valve Plug, Flow Up Through the Port (continued)

Equal Percentage - Flow Up													Equal Percentage Characteristic	
Valve Size	Port Diameter mm	Maximum Travel mm	Flow Coefficient	Valve Opening—Percent of Total Travel										F <sub>L</sub> <sup>(1)</sup>
				10	20	30	40	50	60	70	80	90	100	
DN 25 (1-Inch)	22	20	C <sub>v</sub>	0.673	0.937	1.32	1.89	2.25	3.13	5.05	7.39	10.5	13.7	0.93
			K <sub>v</sub>	0.582	0.810	1.14	1.63	1.94	2.71	4.36	6.39	9.05	11.9	---
			X <sub>T</sub>	0.61	0.59	0.58	0.57	0.74	0.82	0.64	0.58	0.68	0.77	---
			F <sub>d</sub>	0.09	0.11	0.13	0.15	0.18	0.21	0.25	0.31	0.39	0.49	---
	14	20	C <sub>v</sub>	0.139	0.186	0.315	0.511	0.776	1.23	1.97	3.28	5.35	6.89	0.97
			K <sub>v</sub>	0.120	0.161	0.272	0.442	0.671	1.07	1.70	2.84	4.63	5.96	---
			X <sub>T</sub>	0.78	0.71	0.59	0.59	0.58	0.51	0.57	0.51	0.67	0.81	---
			F <sub>d</sub>	0.08	0.08	0.10	0.13	0.16	0.20	0.26	0.33	0.47	0.59	---
	9.5	20	C <sub>v</sub>	0.133	0.222	0.347	0.501	0.699	1.04	1.50	2.15	2.98	3.57	0.95
			K <sub>v</sub>	0.115	0.192	0.300	0.433	0.605	0.900	1.29	1.86	2.58	3.09	---
			X <sub>T</sub>	0.77	0.68	0.65	0.61	0.55	0.55	0.58	0.55	0.59	0.68	---
			F <sub>d</sub>	0.11	0.13	0.16	0.19	0.22	0.28	0.34	0.44	0.58	0.80	---
	9.5 <sup>(2)</sup>	20	C <sub>v</sub>	0.127	0.149	0.176	0.222	0.311	0.440	0.599	0.828	1.14	1.65	0.95
			K <sub>v</sub>	0.110	0.129	0.152	0.192	0.269	0.381	0.518	0.716	0.986	1.43	---
			X <sub>T</sub>	0.311	0.892	0.755	0.681	0.641	0.618	0.595	0.576	0.582	0.543	---
			F <sub>d</sub>	0.09	0.09	0.09	0.11	0.13	0.14	0.20	0.24	0.28	0.35	---
DN 40 (1.5 Inch)	36	20	C <sub>v</sub>	1.01	1.91	2.74	4.24	6.13	8.25	11.5	16.7	22.0	27.2	0.94
			K <sub>v</sub>	0.874	1.65	2.37	3.67	5.30	7.14	9.95	14.4	19.0	23.5	---
			X <sub>T</sub>	0.87	0.93	0.91	0.80	0.89	0.86	0.76	0.79	0.82	0.78	---
			F <sub>d</sub>	0.64	0.80	0.87	0.54	0.55	0.50	0.41	0.40	0.43	0.45	---
	22	20	C <sub>v</sub>	0.591	0.850	1.20	1.79	2.51	3.50	4.93	7.07	11.0	14.3	0.93
			K <sub>v</sub>	0.511	0.735	1.04	1.55	2.17	3.03	4.26	6.12	9.52	12.4	---
			X <sub>T</sub>	0.53	0.51	0.53	0.45	0.45	0.49	0.42	0.47	0.57	0.71	---
			F <sub>d</sub>	0.09	0.11	0.13	0.15	0.18	0.21	0.25	0.31	0.39	0.49	---
	14	20	C <sub>v</sub>	0.103	0.141	0.254	0.440	0.689	1.11	1.84	3.12	5.12	6.87	0.97
			K <sub>v</sub>	0.0891	0.122	0.220	0.381	0.596	0.960	1.59	2.70	4.43	5.94	---
			X <sub>T</sub>	1.00	0.80	0.68	0.67	0.60	0.54	0.55	0.52	0.64	0.77	---
			F <sub>d</sub>	0.08	0.08	0.10	0.13	0.16	0.20	0.26	0.33	0.47	0.59	---
DN 50 (2-Inch)	46	20	C <sub>v</sub>	1.08	1.75	3.75	6.04	9.5	14.9	21.8	30.9	37.7	43.7	0.91
			K <sub>v</sub>	0.931	1.51	3.24	5.22	8.20	12.9	18.9	26.7	32.6	37.8	---
			X <sub>T</sub>	0.73	0.70	0.79	0.81	0.78	0.81	0.76	0.71	0.82	0.85	---
			F <sub>d</sub>	0.70	0.84	0.47	0.48	0.40	0.36	0.37	0.40	0.43	0.45	---
	36	20	C <sub>v</sub>	1.08	2.01	2.80	4.26	6.31	8.38	11.6	17.2	23.1	28.6	0.93
			K <sub>v</sub>	0.931	1.74	2.42	3.69	5.45	7.25	10.0	14.9	20.0	24.7	---
			X <sub>T</sub>	0.71	0.79	0.86	0.81	0.79	0.79	0.73	0.69	0.75	0.75	---
			F <sub>d</sub>	0.64	0.80	0.87	0.54	0.55	0.50	0.41	0.40	0.43	0.45	---
	22	20	C <sub>v</sub>	0.591	0.850	1.20	1.79	2.51	3.50	4.93	7.07	11.0	14.3	0.96
			K <sub>v</sub>	0.511	0.735	1.04	1.55	2.17	3.03	4.26	6.12	9.52	12.4	---
			X <sub>T</sub>	0.71	0.68	0.61	0.62	0.60	0.60	0.57	0.45	0.60	0.71	---
			F <sub>d</sub>	0.09	0.11	0.13	0.15	0.18	0.21	0.25	0.31	0.39	0.49	---

1. At 100% travel.  
2. Restricted trim.  
3. Balanced trim.  
4. Balanced, restricted trim.

-continued-

# GX Control Valve and Actuator

Table 21. Design GX, Equal Percentage Valve Plug, Flow Up Through the Port (continued)

Equal Percentage - Flow Up													Equal Percentage Characteristic	
Valve Size	Port Diameter mm	Maximum Travel mm	Flow Coefficient	Valve Opening—Percent of Total Travel										F <sub>L</sub> <sup>(1)</sup>
				10	20	30	40	50	60	70	80	90	100	
DN 80 (3-Inch)	70	40	C <sub>v</sub>	2.38	6.92	11.5	16.4	22.4	31.9	46.5	63.6	80.6	95.1	0.94
			K <sub>v</sub>	2.06	5.99	9.95	14.2	19.4	27.6	40.2	55.0	69.7	82.3	---
			X <sub>T</sub>	0.83	0.81	0.85	0.83	0.80	0.76	0.72	0.75	0.77	0.80	---
			F <sub>d</sub>	0.82	0.50	0.53	0.53	0.47	0.42	0.40	0.40	0.43	0.45	---
	70 <sup>(3)</sup>	20	C <sub>v</sub>	2.71	4.63	7.60	11.3	17.1	23.7	35.3	50.4	61.6	75.7	0.89
			K <sub>v</sub>	2.34	4.00	6.57	9.79	14.7	20.5	30.5	43.6	53.3	65.5	---
			X <sub>T</sub>	0.54	0.50	0.49	0.51	0.51	0.57	0.51	0.50	0.64	0.68	---
			F <sub>d</sub>	0.06	0.07	0.10	0.12	0.15	0.18	0.22	0.26	0.30	0.34	---
	46	20	C <sub>v</sub>	0.873	1.66	3.41	5.66	8.75	13.8	20.7	30.5	37.1	43.7	0.97
			K <sub>v</sub>	0.755	1.44	2.95	4.90	7.57	11.9	17.9	26.4	32.1	37.8	---
			X <sub>T</sub>	0.75	0.82	0.75	0.82	0.77	0.73	0.78	0.70	0.85	0.88	---
			F <sub>d</sub>	0.70	0.84	0.47	0.48	0.40	0.36	0.37	0.40	0.43	0.45	---
	36	20	C <sub>v</sub>	1.08	2.01	2.80	4.26	6.31	8.38	11.6	17.2	23.1	28.6	0.96
			K <sub>v</sub>	0.934	1.74	2.42	3.68	5.46	7.25	10.0	14.9	20.0	24.7	---
			X <sub>T</sub>	0.84	0.86	0.88	0.84	0.83	0.88	0.79	0.72	0.76	0.85	---
			F <sub>d</sub>	0.64	0.80	0.87	0.54	0.55	0.50	0.41	0.40	0.43	0.45	---
DN 100 (4-Inch)	90	40	C <sub>v</sub>	5.56	13.6	21.1	29.1	40.8	55.8	77.5	117	145	165	0.90
			K <sub>v</sub>	4.81	11.7	18.3	25.1	35.3	48.3	67.0	101	126	143	---
			X <sub>T</sub>	0.93	0.93	0.94	0.90	0.85	0.82	0.82	0.75	0.78	0.80	---
			F <sub>d</sub>	0.39	0.49	0.52	0.48	0.45	0.44	0.33	0.36	0.39	0.41	---
	90 <sup>(3)</sup>	20	C <sub>v</sub>	5.88	9.43	13.1	17.5	27.3	42.4	63.4	85.5	107	128	0.87
			K <sub>v</sub>	5.09	8.16	11.3	15.1	23.6	36.7	54.8	74.0	92.6	111	---
			X <sub>T</sub>	0.55	0.54	0.54	0.55	0.43	0.52	0.57	0.58	0.63	0.67	---
			F <sub>d</sub>	0.07	0.08	0.10	0.11	0.13	0.18	0.22	0.26	0.30	0.34	---
	90 <sup>(4)</sup>	20	C <sub>v</sub>	2.38	3.65	5.64	8.42	12.0	17.4	24.8	36.7	53.0	68.5	0.90
			K <sub>v</sub>	2.06	3.16	4.88	7.28	10.4	15.1	21.5	31.7	45.8	59.3	---
			X <sub>T</sub>	0.68	0.61	0.57	0.55	0.55	0.55	0.56	0.48	0.50	0.58	---
			F <sub>d</sub>	0.04	0.05	0.06	0.08	0.09	0.11	0.14	0.16	0.20	0.24	---
	70	40	C <sub>v</sub>	2.04	5.78	10.6	15.3	20.8	29.8	43.3	61.9	80.6	97.7	0.92
			K <sub>v</sub>	1.76	5.00	9.17	13.2	18.0	25.8	37.5	53.5	69.7	84.5	---
			X <sub>T</sub>	0.79	0.83	0.85	0.85	0.82	0.77	0.73	0.73	0.75	0.76	---
			F <sub>d</sub>	0.82	0.50	0.53	0.53	0.47	0.42	0.40	0.40	0.43	0.45	---
	46	20	C <sub>v</sub>	1.02	1.76	3.58	5.76	8.85	14.1	21.4	30.6	37.9	44.0	0.94
			K <sub>v</sub>	0.88	1.52	3.10	4.98	7.66	12.2	18.5	26.5	32.8	38.1	---
			X <sub>T</sub>	0.69	0.77	0.68	0.81	0.76	0.71	0.72	0.67	0.75	0.79	---
			F <sub>d</sub>	0.70	0.84	0.47	0.48	0.40	0.36	0.37	0.40	0.43	0.45	---

1. At 100% travel.  
2. Restricted trim.  
3. Balanced trim.  
4. Balanced, restricted trim.

-continued-

Table 21. Design GX, Equal Percentage Valve Plug, Flow Up Through the Port (continued)

Equal Percentage - Flow Up													Equal Percentage Characteristic	
Valve Size	Port Diameter	Maximum Travel	Flow Coefficient	Valve Opening—Percent of Total Travel										F <sub>L</sub> <sup>(1)</sup>
	mm	mm		10	20	30	40	50	60	70	80	90	100	
DN 150 (6-Inch)	136	60	C <sub>v</sub>	6.19	17.7	31.7	50.7	82.2	125	180	243	313	372	0.89
			K <sub>v</sub>	5.36	15.3	27.4	43.8	71.1	108	156	210	271	322	---
			X <sub>T</sub>	0.93	0.93	0.94	0.90	0.85	0.82	0.82	0.75	0.78	0.80	---
			F <sub>d</sub>	0.45	0.39	0.33	0.28	0.24	0.22	0.20	0.18	0.17	0.16	---
	136 <sup>(3)</sup>	60	C <sub>v</sub>	13.7	23.1	34.3	48.1	67.3	97.0	145	226	325	370	0.88
			K <sub>v</sub>	11.9	19.9	29.6	41.6	58.2	83.9	125	195	281	320	---
			X <sub>T</sub>	0.55	0.54	0.54	0.55	0.43	0.52	0.57	0.58	0.63	0.67	---
			F <sub>d</sub>	0.09	0.10	0.11	0.13	0.16	0.19	0.22	0.27	0.32	0.37	---
	90 <sup>(2)</sup>	40	C <sub>v</sub>	5.56	13.6	21.1	29.1	40.8	55.8	77.5	117	145	165	0.90
			K <sub>v</sub>	4.81	11.7	18.3	25.1	35.3	48.3	67.0	101	126	143	---
			X <sub>T</sub>	0.93	0.93	0.94	0.90	0.85	0.82	0.82	0.75	0.78	0.80	---
			F <sub>d</sub>	0.39	0.49	0.52	0.48	0.45	0.44	0.33	0.36	0.39	0.41	---

1. At 100% travel.  
2. Restricted trim.  
3. Balanced trim.  
4. Balanced, restricted trim.

# GX Control Valve and Actuator

Table 22. Design GX, Linear Valve Plug, Flow Up Through the Port

Linear - Flow Up														Linear Characteristic
Valve Size	Port Diameter mm	Maximum Travel mm	Flow Coefficient	Valve Opening—Percent of Total Travel										F <sub>L</sub> <sup>(1)</sup>
				10	20	30	40	50	60	70	80	90	100	
DN 15 (0.5 Inch)	9.5	20	C <sub>V</sub>	0.179	0.415	0.713	1.03	1.35	1.70	2.09	2.53	3.01	3.45	0.93
			K <sub>V</sub>	0.155	0.359	0.617	0.891	1.17	1.47	1.81	2.19	2.60	2.98	---
			X <sub>T</sub>	0.55	0.57	0.64	0.63	0.67	0.68	0.71	0.67	0.71	0.71	---
			F <sub>d</sub>	0.12	0.18	0.24	0.29	0.34	0.39	0.45	0.53	0.65	0.80	---
	4.8 <sup>(4)</sup> 9°30'	20	C <sub>V</sub>	0.0360	0.0880	0.160	0.246	0.341	0.436	0.524	0.618	0.726	0.785	0.94
			K <sub>V</sub>	0.0311	0.0761	0.138	0.213	0.295	0.377	0.453	0.535	0.628	0.679	---
			X <sub>T</sub>	0.52	0.55	0.50	0.50	0.53	0.50	0.52	0.53	0.49	0.55	---
			F <sub>d</sub>	0.09	0.09	0.09	0.11	0.13	0.14	0.20	0.24	0.28	0.35	---
	4.8 <sup>(4)</sup> 4°39'	20	C <sub>V</sub>	0.0356	0.0524	0.0736	0.0984	0.127	0.158	0.191	0.224	0.257	0.294	0.93
			K <sub>V</sub>	0.0308	0.0453	0.0637	0.0851	0.110	0.137	0.165	0.194	0.222	0.254	---
			X <sub>T</sub>	0.55	0.54	0.57	0.58	0.57	0.55	0.55	0.56	0.57	0.55	---
			F <sub>d</sub>	0.08	0.10	0.13	0.15	0.17	0.19	0.22	0.24	0.26	0.28	---
	4.8 <sup>(4)</sup> 2°15'	20	C <sub>V</sub>	0.0437	0.0512	0.0597	0.0694	0.0806	0.0929	0.105	0.116	0.126	0.139	0.86
			K <sub>V</sub>	0.0378	0.0443	0.0516	0.0600	0.0697	0.0804	0.0908	0.100	0.109	0.120	---
			X <sub>T</sub>	0.54	0.54	0.54	0.54	0.54	0.53	0.54	0.56	0.57	0.56	---
			F <sub>d</sub>	0.08	0.08	0.09	0.11	0.12	0.13	0.14	0.15	0.16	0.17	---
	4.8 <sup>(4)</sup> 1°8'	20	C <sub>V</sub>	0.0037	0.0055	0.0085	0.0121	0.0163	0.0205	0.0246	0.0284	0.0326	0.0389	0.97
			K <sub>V</sub>	0.0032	0.0047	0.0073	0.0105	0.0141	0.0177	0.0213	0.0246	0.0282	0.0336	---
			X <sub>T</sub>	1.00	0.94	0.81	0.76	0.69	0.64	0.60	0.59	0.60	0.58	---
			F <sub>d</sub>	0.05	0.06	0.06	0.07	0.07	0.08	0.09	0.09	0.10	0.11	---
DN 20 (0.75 Inch)	14	20	C <sub>V</sub>	0.775	1.57	2.38	3.10	3.79	4.51	5.34	6.23	7.05	7.58	0.97
			K <sub>V</sub>	0.670	1.36	2.06	2.68	3.28	3.90	4.62	5.39	6.10	6.55	---
			X <sub>T</sub>	0.62	0.59	0.62	0.61	0.62	0.64	0.65	0.70	0.73	0.72	---
			F <sub>d</sub>	0.16	0.24	0.30	0.35	0.39	0.45	0.52	0.60	0.71	0.79	---
	9.5	20	C <sub>V</sub>	0.219	0.488	0.794	1.13	1.48	1.85	2.31	2.85	3.43	3.84	0.95
			K <sub>V</sub>	0.190	0.422	0.687	0.981	1.28	1.60	2.00	2.47	2.96	3.33	---
			X <sub>T</sub>	0.57	0.59	0.57	0.57	0.54	0.55	0.54	0.52	0.58	0.59	---
			F <sub>d</sub>	0.12	0.18	0.24	0.29	0.34	0.39	0.45	0.53	0.65	0.80	---
	4.8 <sup>(4)</sup> 9°30'	20	C <sub>V</sub>	0.0360	0.0880	0.160	0.246	0.341	0.436	0.524	0.618	0.726	0.785	0.94
			K <sub>V</sub>	0.0311	0.0761	0.138	0.213	0.295	0.377	0.453	0.535	0.628	0.679	---
			X <sub>T</sub>	0.52	0.55	0.50	0.50	0.53	0.50	0.52	0.53	0.49	0.55	---
			F <sub>d</sub>	0.10	0.15	0.19	0.24	0.29	0.33	0.38	0.42	0.47	0.51	---
	4.8 <sup>(4)</sup> 4°39'	20	C <sub>V</sub>	0.0356	0.0524	0.0736	0.0984	0.127	0.158	0.191	0.224	0.257	0.294	0.93
			K <sub>V</sub>	0.0308	0.0453	0.0637	0.0851	0.110	0.137	0.165	0.194	0.222	0.254	---
			X <sub>T</sub>	0.55	0.54	0.57	0.58	0.57	0.55	0.55	0.56	0.57	0.55	---
			F <sub>d</sub>	0.08	0.10	0.13	0.15	0.17	0.19	0.22	0.24	0.26	0.28	---
	4.8 <sup>(4)</sup> 2°15'	20	C <sub>V</sub>	0.0437	0.0512	0.0597	0.0694	0.0806	0.0929	0.105	0.116	0.126	0.139	0.86
			K <sub>V</sub>	0.0378	0.0443	0.0516	0.0600	0.0697	0.0804	0.0908	0.100	0.109	0.120	---
			X <sub>T</sub>	0.54	0.54	0.54	0.54	0.54	0.53	0.54	0.56	0.57	0.56	---
			F <sub>d</sub>	0.08	0.08	0.09	0.11	0.12	0.13	0.14	0.15	0.16	0.17	---
4.8 <sup>(4)</sup> 1°8'	20	C <sub>V</sub>	0.0037	0.0055	0.0085	0.0121	0.0163	0.0205	0.0246	0.0284	0.0326	0.0389	0.97	
		K <sub>V</sub>	0.0032	0.0047	0.0073	0.0105	0.0141	0.0177	0.0213	0.0246	0.0282	0.0336	---	
		X <sub>T</sub>	1.00	0.94	0.81	0.76	0.69	0.64	0.60	0.59	0.60	0.58	---	
		F <sub>d</sub>	0.05	0.06	0.06	0.07	0.07	0.08	0.09	0.09	0.10	0.11	---	

1. At 100% travel.  
2. Balanced trim.  
3. Balanced, restricted trim.  
4. Micro-Flow trim.

-continued-

Table 22. Design GX, Linear Valve Plug, Flow Up Through the Port (continued)

Linear - Flow Up														Linear Characteristic
Valve Size	Port Diameter mm	Maximum Travel mm	Flow Coefficient	Valve Opening—Percent of Total Travel										F <sub>L</sub> <sup>(1)</sup>
				10	20	30	40	50	60	70	80	90	100	
DN 25 (1-Inch)	22	20	C <sub>V</sub>	1.72	3.06	4.50	7.04	8.52	9.74	11.1	12.7	14.6	15.5	0.94
			K <sub>V</sub>	1.49	2.64	3.90	6.09	7.37	8.43	9.58	10.9	12.6	13.4	---
			X <sub>T</sub>	0.51	0.58	0.60	0.44	0.47	0.52	0.56	0.68	0.74	0.80	---
			F <sub>d</sub>	0.14	0.19	0.24	0.29	0.33	0.37	0.42	0.46	0.53	0.61	---
	14	20	C <sub>V</sub>	0.685	1.46	2.28	3.05	3.81	4.56	5.42	6.34	7.21	7.80	0.96
			K <sub>V</sub>	0.592	1.26	1.97	2.64	3.29	3.95	4.69	5.48	6.24	6.75	---
			X <sub>T</sub>	0.73	0.64	0.62	0.60	0.59	0.59	0.60	0.63	0.67	0.66	---
			F <sub>d</sub>	0.16	0.24	0.30	0.35	0.39	0.45	0.52	0.60	0.71	0.79	---
	9.5	20	C <sub>V</sub>	0.187	0.453	0.769	1.10	1.42	1.79	2.22	2.73	3.29	3.70	0.94
			K <sub>V</sub>	0.161	0.392	0.665	0.952	1.23	1.55	1.92	2.36	2.85	3.20	---
			X <sub>T</sub>	0.59	0.56	0.55	0.53	0.58	0.57	0.60	0.58	0.63	0.63	---
			F <sub>d</sub>	0.12	0.18	0.24	0.29	0.34	0.39	0.45	0.53	0.65	0.80	---
	4.8 <sup>(4)</sup> 9°30'	20	C <sub>V</sub>	0.0360	0.0880	0.160	0.246	0.341	0.436	0.524	0.618	0.726	0.785	0.94
			K <sub>V</sub>	0.0311	0.0761	0.138	0.213	0.295	0.377	0.453	0.535	0.628	0.679	---
			X <sub>T</sub>	0.52	0.55	0.50	0.50	0.53	0.50	0.52	0.53	0.49	0.55	---
			F <sub>d</sub>	0.10	0.15	0.19	0.24	0.29	0.33	0.38	0.42	0.47	0.51	---
	4.8 <sup>(4)</sup> 4°39'	20	C <sub>V</sub>	0.0356	0.0524	0.0736	0.0984	0.127	0.158	0.191	0.224	0.257	0.294	0.93
			K <sub>V</sub>	0.0308	0.0453	0.0637	0.0851	0.110	0.137	0.165	0.194	0.222	0.254	---
			X <sub>T</sub>	0.55	0.54	0.57	0.58	0.57	0.55	0.55	0.56	0.57	0.55	---
			F <sub>d</sub>	0.08	0.10	0.13	0.15	0.17	0.19	0.22	0.24	0.26	0.28	---
	4.8 <sup>(4)</sup> 2°15'	20	C <sub>V</sub>	0.0437	0.0512	0.0597	0.0694	0.0806	0.0929	0.105	0.116	0.126	0.139	0.86
			K <sub>V</sub>	0.0378	0.0443	0.0516	0.0600	0.0697	0.0804	0.0908	0.100	0.109	0.120	---
			X <sub>T</sub>	0.54	0.54	0.54	0.54	0.54	0.53	0.54	0.56	0.57	0.56	---
			F <sub>d</sub>	0.08	0.08	0.09	0.11	0.12	0.13	0.14	0.15	0.16	0.17	---
4.8 <sup>(4)</sup> 1°8'	20	C <sub>V</sub>	0.0037	0.0055	0.0085	0.0121	0.0163	0.0205	0.0246	0.0284	0.0326	0.0389	0.97	
		K <sub>V</sub>	0.0032	0.0047	0.0073	0.0105	0.0141	0.0177	0.0213	0.0246	0.0282	0.0336	---	
		X <sub>T</sub>	1.00	0.94	0.81	0.76	0.69	0.64	0.60	0.59	0.60	0.58	---	
		F <sub>d</sub>	0.05	0.06	0.06	0.07	0.07	0.08	0.09	0.09	0.10	0.11	---	
DN 40 (1.5 Inch)	36	20	C <sub>V</sub>	1.18	4.50	7.46	11.0	14.1	16.8	20.3	24.4	28.8	32.0	0.93
			K <sub>V</sub>	1.02	3.89	6.45	9.5	12.2	14.5	17.6	21.1	24.9	27.7	---
			X <sub>T</sub>	0.88	0.75	0.88	0.82	0.80	0.88	0.85	0.80	0.78	0.78	---
			F <sub>d</sub>	0.30	0.42	0.47	0.49	0.51	0.52	0.50	0.48	0.47	0.48	---
	22	20	C <sub>V</sub>	1.41	2.76	4.20	5.76	7.32	8.85	10.5	12.9	15.1	17.2	0.95
			K <sub>V</sub>	1.22	2.39	3.63	4.98	6.33	7.66	9.08	11.2	13.1	14.9	---
			X <sub>T</sub>	0.68	0.58	0.58	0.59	0.58	0.59	0.65	0.60	0.68	0.75	---
			F <sub>d</sub>	0.08	0.10	0.13	0.15	0.17	0.19	0.22	0.24	0.26	0.28	---
	14	20	C <sub>V</sub>	0.676	1.55	2.27	3.03	3.77	4.55	5.44	6.47	7.36	8.25	0.96
			K <sub>V</sub>	0.585	1.34	1.96	2.62	3.26	3.94	4.71	5.60	6.37	7.14	---
			X <sub>T</sub>	0.58	0.50	0.59	0.62	0.59	0.58	0.60	0.63	0.67	0.64	---
			F <sub>d</sub>	0.08	0.08	0.09	0.11	0.12	0.13	0.14	0.15	0.16	0.17	---

1. At 100% travel.  
2. Balanced trim.  
3. Balanced, restricted trim.  
4. Micro-Flow trim.

-continued-

# GX Control Valve and Actuator

Table 22. Design GX, Linear Valve Plug, Flow Up Through the Port (continued)

Linear - Flow Up														Linear Characteristic
Valve Size	Port Diameter mm	Maximum Travel mm	Flow Coefficient	Valve Opening—Percent of Total Travel										F <sub>L</sub> <sup>(1)</sup>
				10	20	30	40	50	60	70	80	90	100	
DN 50 (2-Inch)	46	20	C <sub>V</sub>	2.90	7.53	12.6	17.5	22.1	27.8	34.1	41.6	45.7	48.6	0.91
			K <sub>V</sub>	2.51	6.51	10.9	15.1	19.1	24.0	29.5	36.0	39.5	42.0	---
			X <sub>T</sub>	0.71	0.87	0.81	0.87	0.85	0.82	0.79	0.82	0.85	0.84	---
			F <sub>d</sub>	0.25	0.36	0.42	0.46	0.47	0.46	0.46	0.47	0.48	0.50	---
	36	20	C <sub>V</sub>	1.69	5.05	8.37	11.6	14.8	17.9	20.9	24.7	29.2	33.9	0.93
			K <sub>V</sub>	1.47	4.37	7.24	10.0	12.8	15.5	18.0	21.3	25.3	29.3	---
			X <sub>T</sub>	0.73	0.76	0.84	0.81	0.82	0.84	0.87	0.85	0.84	0.82	---
			F <sub>d</sub>	0.30	0.42	0.47	0.49	0.51	0.52	0.50	0.48	0.47	0.48	---
	22	20	C <sub>V</sub>	1.58	3.01	4.51	6.02	7.63	9.10	10.9	13.1	15.1	17.2	0.93
			K <sub>V</sub>	1.37	2.60	3.90	5.21	6.60	7.87	9.40	11.3	13.0	14.9	---
			X <sub>T</sub>	0.66	0.62	0.62	0.61	0.61	0.60	0.58	0.55	0.62	0.68	---
			F <sub>d</sub>	0.08	0.10	0.13	0.15	0.17	0.19	0.22	0.24	0.26	0.28	---
DN 80 (3-Inch)	70	40	C <sub>V</sub>	9.74	20.9	32.9	46.2	59.6	74.3	87.5	97.2	109	117	0.89
			K <sub>V</sub>	8.43	18.1	28.5	40.0	51.6	64.3	75.7	84.1	94.3	101	---
			X <sub>T</sub>	0.62	0.85	0.83	0.81	0.81	0.81	0.81	0.85	0.80	0.77	---
			F <sub>d</sub>	0.33	0.43	0.47	0.48	0.49	0.50	0.50	0.51	0.51	0.51	---
	70 <sup>(2)</sup>	20	C <sub>V</sub>	10.6	21.3	31.9	42.7	53.6	63.8	74.1	85.0	94.4	102	0.85
			K <sub>V</sub>	9.17	18.4	27.6	36.9	46.4	55.2	64.1	73.5	81.7	88.2	---
			X <sub>T</sub>	0.67	0.68	0.66	0.65	0.64	0.67	0.66	0.63	0.63	0.65	---
			F <sub>d</sub>	0.12	0.17	0.21	0.25	0.28	0.31	0.34	0.36	0.39	0.41	---
	46	20	C <sub>V</sub>	2.09	7.74	12.0	16.5	21.2	26.6	33.0	40.6	46.5	51.8	0.97
			K <sub>V</sub>	1.81	6.70	10.4	14.3	18.3	23.0	28.5	35.1	40.2	44.8	---
			X <sub>T</sub>	0.65	0.62	0.79	0.85	0.88	0.85	0.88	0.83	0.88	0.90	---
			F <sub>d</sub>	0.25	0.36	0.42	0.46	0.47	0.46	0.46	0.47	0.48	0.50	---
36	20	C <sub>V</sub>	1.17	4.87	7.76	11.1	14.3	17.3	19.3	23.2	27.8	33.3	0.97	
		K <sub>V</sub>	1.01	4.21	6.71	9.58	12.4	14.9	16.7	20.1	24.1	28.8	---	
		X <sub>T</sub>	0.74	0.59	0.81	0.80	0.82	0.83	0.94	0.96	0.93	0.87	---	
		F <sub>d</sub>	0.30	0.42	0.47	0.49	0.51	0.52	0.50	0.48	0.47	0.48	---	
DN 100 (4-Inch)	90	40	C <sub>V</sub>	18.2	39.6	59.0	82.4	104	124	141	156	171	184	0.91
			K <sub>V</sub>	15.8	34.3	51.0	71.3	90.0	108	122	135	147	159	---
			X <sub>T</sub>	0.78	0.84	0.90	0.85	0.86	0.91	0.91	0.90	0.85	0.82	---
			F <sub>d</sub>	0.26	0.36	0.41	0.43	0.45	0.46	0.47	0.48	0.48	0.48	---
	90 <sup>(2)</sup>	20	C <sub>V</sub>	12.3	28.5	44.6	60.2	77.6	95.4	112	130	143	151	0.82
			K <sub>V</sub>	10.6	24.7	38.6	52.1	67.1	82.5	96.9	112	124	131	---
			X <sub>T</sub>	0.71	0.65	0.58	0.67	0.59	0.57	0.58	0.61	0.59	0.64	---
			F <sub>d</sub>	0.11	0.16	0.20	0.23	0.27	0.29	0.31	0.34	0.36	0.39	---
	90 <sup>(3)</sup>	20	C <sub>V</sub>	5.99	13.6	22.3	31.5	40.4	49.6	59.2	69.0	79.6	92.3	0.82
			K <sub>V</sub>	5.18	11.8	19.3	27.2	34.9	42.9	51.2	59.7	68.9	79.8	---
			X <sub>T</sub>	0.60	0.59	0.61	0.58	0.59	0.62	0.59	0.58	0.57	0.52	---
			F <sub>d</sub>	0.07	0.11	0.14	0.16	0.18	0.20	0.22	0.24	0.25	0.27	---
70	40	C <sub>V</sub>	9.04	22.1	33.8	47.0	60.8	76.9	92.0	107	119	128	0.94	
		K <sub>V</sub>	7.82	19.1	29.2	40.7	52.6	66.5	79.6	92.6	103	111	---	
		X <sub>T</sub>	0.80	0.82	0.84	0.83	0.81	0.80	0.79	0.81	0.81	0.82	---	
		F <sub>d</sub>	0.33	0.43	0.47	0.48	0.49	0.50	0.50	0.51	0.51	0.51	---	
46	20	C <sub>V</sub>	2.37	7.98	13.1	17.3	21.9	27.1	33.2	40.3	46.8	52.2	0.96	
		K <sub>V</sub>	2.05	6.90	11.3	15.0	19.0	23.5	28.7	34.8	40.5	45.2	---	
		X <sub>T</sub>	0.70	0.70	0.78	0.88	0.90	0.88	0.85	0.83	0.83	0.83	---	
		F <sub>d</sub>	0.25	0.36	0.42	0.46	0.47	0.46	0.46	0.47	0.48	0.50	---	

1. At 100% travel.  
2. Balanced trim.  
3. Balanced, restricted trim.  
4. Micro-Flow trim.

-continued-

Table 22. Design GX, Linear Valve Plug, Flow Up Through the Port (continued)

Linear - Flow Up														Linear Characteristic
Valve Size	Port Diameter	Maximum Travel	Flow Coefficient	Valve Opening—Percent of Total Travel										F <sub>L</sub> <sup>(1)</sup>
	mm	mm		10	20	30	40	50	60	70	80	90	100	
DN 150 (6-Inch)	136	60	C <sub>V</sub>	26.5	70.5	96.8	118	143	167	203	251	318	377	0.90
			K <sub>V</sub>	25.5	61.0	83.7	102	123	144	175	217	275	326	---
			X <sub>T</sub>	0.78	0.84	0.90	0.85	0.86	0.91	0.91	0.90	0.85	0.82	---
			F <sub>d</sub>	0.29	0.27	0.24	0.22	0.20	0.19	0.17	0.16	0.15	0.14	---
	136 <sup>(2)</sup>	60	C <sub>V</sub>	36.4	79.0	119	162	210	258	306	342	368	389	0.85
			K <sub>V</sub>	31.5	68.3	103	140	181	223	264	296	318	337	---
			X <sub>T</sub>	0.71	0.65	0.58	0.67	0.59	0.57	0.58	0.61	0.59	0.64	---
			F <sub>d</sub>	0.13	0.19	0.23	0.27	0.32	0.36	0.40	0.43	0.47	0.50	---
	90 <sup>(3)</sup>	40	C <sub>V</sub>	18.2	39.6	59.0	82.4	104	124	141	156	171	184	0.91
			K <sub>V</sub>	15.8	34.3	51.0	71.3	90.0	108	122	135	147	159	---
			X <sub>T</sub>	0.78	0.84	0.90	0.85	0.86	0.91	0.91	0.90	0.85	0.82	---
			F <sub>d</sub>	0.26	0.36	0.41	0.43	0.45	0.46	0.47	0.48	0.48	0.48	---

1. At 100% travel.  
2. Balanced trim.  
3. Restricted trim.  
4. Micro-Flow trim.

Table 23. Design GX, Whisper Trim® III, Flow Up Through the Port

Whisper Trim III- Flow Up														Linear Characteristic
Valve Size	Port Diameter	Maximum Travel	Flow Coefficient	Valve Opening—Percent of Total Travel										F <sub>L</sub> <sup>(1)</sup>
	mm	mm		10	20	30	40	50	60	70	80	90	100	
DN80 (3-Inch) Level A1	70	40	C <sub>V</sub>	2.2	11.2	22.4	31.6	40.4	51.2	60.2	68.5	76.9	85.5	0.818
			K <sub>V</sub>	1.9	9.7	19.4	27.3	34.9	44.3	52.1	59.3	66.5	74.0	---
			X <sub>T</sub>	0.861	0.714	0.584	0.600	0.589	0.572	0.590	0.616	0.637	0.646	---
			F <sub>d</sub>	0.431	0.176	0.131	0.110	0.096	0.085	0.078	0.072	0.067	0.063	---
DN100 (4-Inch) Level A1	90	40	C <sub>V</sub>	2.6	14.0	29.1	41.5	53.6	67.9	81.3	93.8	107	119	0.785
			K <sub>V</sub>	2.2	12.1	25.2	35.9	46.4	58.7	70.3	81.1	92.6	103	---
			X <sub>T</sub>	0.870	0.726	0.573	0.561	0.558	0.533	0.537	0.548	0.581	0.602	---
			F <sub>d</sub>	0.379	0.155	0.115	0.097	0.084	0.075	0.069	0.063	0.059	0.055	---
	70 <sup>(2)</sup>	40	C <sub>V</sub>	2.2	11.2	22.4	31.6	40.4	51.2	60.2	68.5	76.9	85.5	0.818
			K <sub>V</sub>	1.9	9.7	19.4	27.3	34.9	44.3	52.1	59.3	66.5	74.0	---
			X <sub>T</sub>	0.861	0.714	0.584	0.600	0.589	0.572	0.590	0.616	0.637	0.646	---
			F <sub>d</sub>	0.431	0.176	0.131	0.110	0.096	0.085	0.078	0.072	0.067	0.063	---
DN150 (6-Inch) Level A1	136	60	C <sub>V</sub>	37.9	75.4	112	149	184	218	252	284	315	344	0.770
			K <sub>V</sub>	32.8	65.2	97.1	129	159	189	218	245	272	298	---
			X <sub>T</sub>	0.868	0.730	0.570	0.550	0.560	0.587	0.603	0.630	0.680	0.714	---
			F <sub>d</sub>	0.134	0.087	0.070	0.060	0.053	0.048	0.044	0.041	0.039	0.037	---
	90 <sup>(2)</sup>	40	C <sub>V</sub>	2.6	14.0	29.1	41.5	53.6	67.9	81.3	93.8	107	119	0.785
			K <sub>V</sub>	2.2	12.1	25.2	35.9	46.4	58.7	70.3	81.1	92.6	103	---
			X <sub>T</sub>	0.870	0.726	0.573	0.561	0.558	0.533	0.537	0.548	0.581	0.602	---
			F <sub>d</sub>	0.379	0.155	0.115	0.097	0.084	0.075	0.069	0.063	0.059	0.055	---

1. At 100% travel.  
2. Unbalanced, restricted trim.

## Note

**Neither Emerson, Emerson Process Management, Fisher, nor any of their affiliated entities assumes responsibility for the selection, use and maintenance of any product. Responsibility for the selection, use, and maintenance of any product remains with the purchaser and end-user.**

FIELDVUE, Micro-Flow, ValveLink, Whisper Trim, and Fisher are marks owned by Fisher Controls International LLC, a member of the Emerson Process Management business division of Emerson Electric Co. Emerson Process Management, Emerson, and the Emerson logo are trademarks and service marks of Emerson Electric Co. HART is a mark owned by the HART Communications Foundation. FOUNDATION fieldbus is a mark owned by the Fieldbus Foundation. All other marks are the property of their respective owners. This product may be covered by one or more of the following patents: 6,866,244; 6,827,001; and 6,789,784 or under pending patents.

*The contents of this publication are presented for informational purposes only, and while every effort has been made to ensure their accuracy, they are not to be construed as warranties or guarantees, express or implied, regarding the products or services described herein or their use or applicability. We reserve the right to modify or improve the designs or specifications of such products at any time without notice.*

Neither Emerson, Emerson Process Management, Fisher, nor any of their affiliated entities assumes responsibility for the selection, use and maintenance of any product. Responsibility for the selection, use and maintenance of any product remains with the purchaser and end-user.

## Emerson Process Management

### Fisher

Marshalltown, Iowa 50158 USA  
Cernay 68700 France  
Sao Paulo 05424 Brazil  
Singapore 128461

[www.Fisher.com](http://www.Fisher.com)

